



# AiP74LVC2G06

## Dual Inverter (Open-Drain)

### Product Specification

**Specification Revision History:**

Version	Date	Description
2024-04-A0	2024-04	New
2024-09-A1	2024-09	Modify the parameters



# Contents

<b>1、 General Description.....</b>	<b>3</b>
<b>2、 Block Diagram And Pin Description .....</b>	<b>4</b>
2.1、 Block Diagram .....	4
2.2、 Pin Configurations.....	4
2.3、 Pin Description .....	4
2.4、 Function Table.....	4
<b>3、 Electrical Parameter .....</b>	<b>5</b>
3.1、 Absolute Maximum Ratings.....	5
3.2、 Recommended Operating Conditions.....	5
3.3、 Electrical Characteristics .....	6
3.3.1、 DC Characteristics 1 .....	6
3.3.2、 DC Characteristics 2 .....	7
3.3.3、 AC Characteristics 1 .....	7
3.3.4、 AC Characteristics 2 .....	8
<b>4、 Testing Circuit .....</b>	<b>8</b>
4.1、 AC Testing Circuit .....	8
4.2、 Test Data .....	8
4.3、 AC Testing Waveforms.....	9
4.4、 Measurement Points .....	9
<b>5、 Package Information .....</b>	<b>10</b>
5.1、 SOT23-6.....	10
5.2、 SOT363 .....	11
5.3、 XSON6(1*1.45*0.55-0.5) .....	12
5.4、 XSON6(1*1*0.45-0.35) .....	13
<b>6、 Statements And Notes .....</b>	<b>14</b>
6.1、 The name and content of Hazardous substances or Elements in the product .....	14
6.2、 Notes .....	14



## 1、General Description

The AiP74LVC2G06 provides two inverters. The output of this device is an open drain and can be connected to other open-drain outputs to implement active-LOW wired-OR or active-HIGH wired-AND functions.

The input can be driven from either 3.3V or 5V devices. This feature allows the use of this device in a mixed 3.3V and 5V environment.

### Features:

- Wide supply voltage range from 1.65V to 5.5V
- Inputs accept voltages to 5.5 V
- 24mA output drive at 3.0V
- High-impedance when  $V_{CC}=0V$
- Temperature range:  $-40^{\circ}C$  to  $+125^{\circ}C$
- Packaging information: SOT23-6/SOT363/XSON6

### Ordering Information:

#### Reel packing specifications:

Part number	Packaging form	Marking code	Reel quantity	Boxed reel quantity	Notes
AiP74LVC2G06GB236.TR	SOT23-6	BFXX	3000 PCS/reel	30000 PCS/box	Dimensions of plastic enclosure: 2.9mm×1.6mm Pin spacing: 0.95mm
AiP74LVC2G06GC363.TR	SOT363	BFXX	3000 PCS/reel	30000 PCS/box	Dimensions of plastic enclosure: 2.1mm×1.3mm Pin spacing: 0.65mm
AiP74LVC2G06EA6.TR	XSON6	BFXX	5000 PCS/reel	25000 PCS/box	Dimensions of plastic enclosure: 1.45mm×1.0mm Pin spacing: 0.5mm
AiP74LVC2G06ED6.TR	XSON6	BFXX	5000 PCS/reel	25000 PCS/box	Dimensions of plastic enclosure: 1.0mm×1.0mm Pin spacing: 0.35mm

Note 1: “XX” refers to variable content, meaning year and package batch serial number.

Note 2: If the physical information is inconsistent with the ordering information, please refer to the actual product.



## 2、Block Diagram And Pin Description

### 2.1、Block Diagram

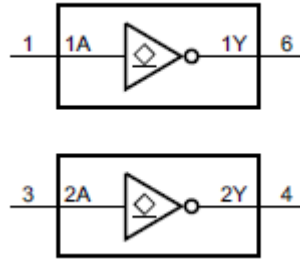
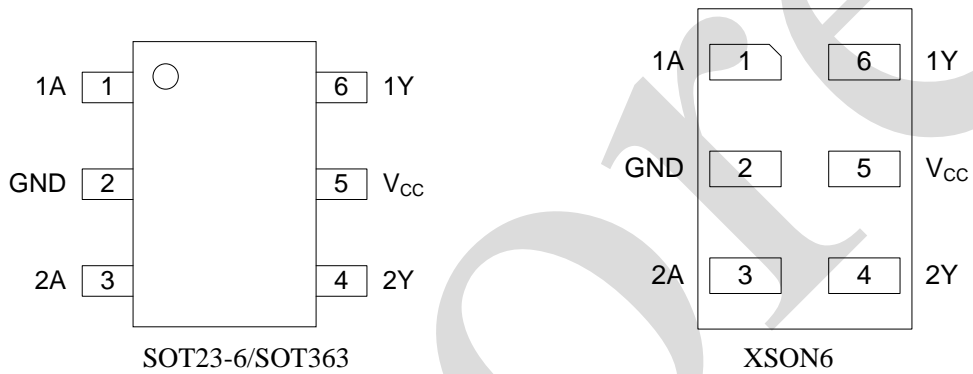

Figure 1. Block Diagram

### 2.2、Pin Configurations



### 2.3、Pin Description

Pin No.	Pin Name	Description
1	1A	data input
2	GND	ground (0V)
3	2A	data input
4	2Y	data output
5	V <sub>CC</sub>	supply voltage
6	1Y	data output

### 2.4、Function Table

Input	Output
nA	nY
L	Z
H	L

Note: H=HIGH voltage level; L=LOW voltage level; Z=high-impedance OFF-state.



## 3、Electrical Parameter

### 3.1、Absolute Maximum Ratings

(Voltages are referenced to GND (ground=0V), unless otherwise specified.)

Parameter	Symbol	Conditions	Min.	Max.	Unit
supply voltage	$V_{CC}$	-	-0.5	+6.5	V
input voltage	$V_I$	-	-0.5	+6.5	V
output voltage	$V_O$	Active mode	-0.5	+6.5	V
		Power-down mode; $V_{CC}=0V$	-0.5	+6.5	V
supply current	$I_{CC}$	-	-	100	mA
ground current	$I_{GND}$	-	-100	-	mA
input clamping current	$I_{IK}$	$V_I < 0V$	-50	-	mA
output current	$I_O$	$V_O=0V$ to $V_{CC}$	-	50	mA
output clamping current	$I_{OK}$	$V_O > V_{CC}$ or $V_O < 0V$	-	$\pm 50$	mA
storage temperature	$T_{stg}$	-	-65	+150	$^{\circ}C$
soldering temperature	$T_L$	10s	260		$^{\circ}C$

### 3.2、Recommended Operating Conditions

Parameter	Symbol	Conditions	Min.	Typ.	Max.	Unit
supply voltage	$V_{CC}$	-	1.65	-	5.5	V
input voltage	$V_I$	-	0	-	5.5	V
output voltage	$V_O$	Active mode	0	-	5.5	V
		Power-down mode; $V_{CC}=0V$	0	-	5.5	V
ambient temperature	$T_{amb}$	-	-40	-	+125	$^{\circ}C$
input transition rise and fall rate	$\Delta t/\Delta V$	$V_{CC}=1.65V$ to $2.7V$	-	-	20	ns/V
		$V_{CC}=2.7V$ to $5.5V$	-	-	10	ns/V



## 3.3、Electrical Characteristics

### 3.3.1、DC Characteristics 1

( $T_{amb}=-40^{\circ}\text{C}$  to  $+85^{\circ}\text{C}$ , voltages are referenced to GND (ground=0V), unless otherwise specified.)

Parameter	Sym	V <sub>CC</sub>	Conditions	Min.	Typ.	Max.	Unit
HIGH-level input voltage	V <sub>IH</sub>	1.65V to 1.95V	-	$0.65 \times V_{CC}$	-	-	V
		2.3V to 2.7V	-	1.7	-	-	V
		2.7V to 3.6V	-	2.0	-	-	V
		4.5V to 5.5V	-	$0.7 \times V_{CC}$	-	-	V
LOW-level input voltage	V <sub>IL</sub>	1.65V to 1.95V	-	-	-	$0.35 \times V_{CC}$	V
		2.3V to 2.7V	-	-	-	0.7	V
		2.7V to 3.6V	-	-	-	0.8	V
		4.5V to 5.5V	-	-	-	$0.3 \times V_{CC}$	V
LOW-level output voltage	V <sub>OL</sub>	1.65V to 5.5V	I <sub>O</sub> =100uA	-	-	0.10	V
		1.65V	I <sub>O</sub> =4mA	-	-	0.45	V
		2.3V	I <sub>O</sub> =8mA	-	-	0.30	V
		2.7V	I <sub>O</sub> =12mA	-	-	0.40	V
		3.0V	I <sub>O</sub> =24mA	-	-	0.55	V
		4.5V	I <sub>O</sub> =32mA	-	-	0.55	V
input leakage current	I <sub>I</sub>	0V to 5.5V	V <sub>I</sub> =5.5V or GND	-	-	±1	uA
OFF-state output current	I <sub>OZ</sub>	5.5V	V <sub>I</sub> =V <sub>IH</sub> or V <sub>IL</sub> ; V <sub>O</sub> =5.5V or GND	-	-	±2	uA
power-off leakage current	I <sub>OFF</sub>	0V	V <sub>I</sub> or V <sub>O</sub> =5.5V	-	-	±2	uA
supply current	I <sub>CC</sub>	1.65V to 5.5V	V <sub>I</sub> =V <sub>CC</sub> or GND; I <sub>O</sub> =0A	-	-	4	uA
additional supply current	ΔI <sub>CC</sub>	2.3V to 5.5V	per input pin; V <sub>I</sub> = V <sub>CC</sub> -0.6V; I <sub>O</sub> =0A	-	-	500	uA

Note: All typical values are measured at  $T_{amb}=25^{\circ}\text{C}$ .



### 3.3.2、DC Characteristics 2

( $T_{amb}=-40^{\circ}\text{C}$  to  $+125^{\circ}\text{C}$ , voltages are referenced to GND (ground = 0V), unless otherwise specified.)

Parameter	Sym	V <sub>CC</sub>	Conditions	Min.	Typ.	Max.	Unit
HIGH-level input voltage	V <sub>IH</sub>	1.65V to 1.95V	-	$0.65 \times V_{CC}$	-	-	V
		2.3V to 2.7V	-	1.7	-	-	V
		2.7V to 3.6V	-	2.0	-	-	V
		4.5V to 5.5V	-	$0.7 \times V_{CC}$	-	-	V
LOW-level input voltage	V <sub>IL</sub>	1.65V to 1.95V	-	-	-	$0.35 \times V_{CC}$	V
		2.3V to 2.7V	-	-	-	0.7	V
		2.7V to 3.6V	-	-	-	0.8	V
		4.5V to 5.5V	-	-	-	$0.3 \times V_{CC}$	V
LOW-level output voltage	V <sub>OL</sub>	1.65V to 5.5V	I <sub>O</sub> =100uA	-	-	0.10	V
		1.65V	I <sub>O</sub> =4mA	-	-	0.70	V
		2.3V	I <sub>O</sub> =8mA	-	-	0.45	V
		2.7V	I <sub>O</sub> =12mA	-	-	0.60	V
		3.0V	I <sub>O</sub> =24mA	-	-	0.80	V
		4.5V	I <sub>O</sub> =32mA	-	-	0.80	V
input leakage current	I <sub>I</sub>	0V to 5.5V	V <sub>I</sub> =5.5V or GND	-	-	±1	uA
OFF-state output current	I <sub>OZ</sub>	5.5V	V <sub>I</sub> =V <sub>IH</sub> or V <sub>IL</sub> ; V <sub>O</sub> =5.5V or GND	-	-	±2	uA
power-off leakage current	I <sub>OFF</sub>	0V	V <sub>I</sub> or V <sub>O</sub> =5.5V	-	-	±2	uA
supply current	I <sub>CC</sub>	1.65V to 5.5V	V <sub>I</sub> =V <sub>CC</sub> or GND; I <sub>O</sub> =0A	-	-	4	uA
additional supply current	ΔI <sub>CC</sub>	2.3V to 5.5V	per input pin; V <sub>I</sub> = V <sub>CC</sub> -0.6V; I <sub>O</sub> =0A	-	-	500	uA

### 3.3.3、AC Characteristics 1

( $T_{amb}=-40^{\circ}\text{C}$  to  $+85^{\circ}\text{C}$ , voltages are referenced to GND (ground = 0V), unless otherwise specified.)

Parameter	Symbol	V <sub>CC</sub>	Conditions	Min.	Typ.	Max.	Unit
nA to nY propagation delay	t <sub>PLZ</sub> , t <sub>PZL</sub>	1.65V to 1.95V	see Figure 3	-	3.2	6.5	ns
		2.3V to 2.7V		-	2.0	3.9	ns
		2.7V		-	2.6	4.2	ns
		3.0V to 3.6V		-	2.3	3.4	ns
		4.5V to 5.5V		-	1.6	2.9	ns

Note: Typical values are measured at  $T_{amb}=25^{\circ}\text{C}$  and  $V_{CC}=1.8\text{V}$ , 2.5V, 2.7V, 3.3V and 5.0V respectively.



### 3.3.4、AC Characteristics 2

( $T_{amb}=-40^{\circ}C$  to  $+125^{\circ}C$ , voltages are referenced to GND (ground = 0V), unless otherwise specified.)

Parameter	Symbol	V <sub>CC</sub>	Conditions	Min.	Typ.	Max.	Unit
nA to nY propagation delay	t <sub>PLZ</sub> , t <sub>PZL</sub>	1.65V to 1.95V	see Figure 3	-	-	8.2	ns
		2.3V to 2.7V		-	-	4.9	ns
		2.7V		-	-	5.3	ns
		3.0V to 3.6V		-	-	4.3	ns
		4.5V to 5.5V		-	-	3.7	ns

## 4、Testing Circuit

### 4.1、AC Testing Circuit

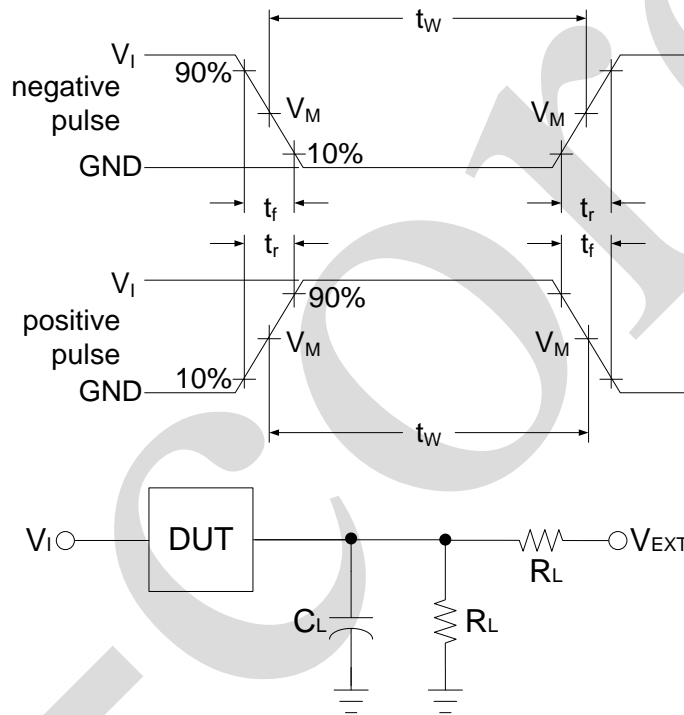

Figure 2 AC Testing Circuit

Definitions for test circuit:

$R_L$ =Load resistance.

$C_L$ =Load capacitance including jig and probe capacitance.

### 4.2、Test Data

Supply voltage	Input		Load		V <sub>EXT</sub>
V <sub>CC</sub>	V <sub>I</sub>	t <sub>r</sub> = t <sub>f</sub>	C <sub>L</sub>	R <sub>L</sub>	t <sub>PZL</sub> /t <sub>PLZ</sub>
1.65V to 1.95V	V <sub>CC</sub>	≤ 3ns	30pF	1kΩ	2×V <sub>CC</sub>
2.3V to 2.7V	V <sub>CC</sub>	≤ 3ns	30pF	500Ω	2×V <sub>CC</sub>
2.7V	V <sub>CC</sub>	≤ 3ns	50pF	500Ω	2×V <sub>CC</sub>
3.0V to 3.6V	V <sub>CC</sub>	≤ 3ns	50pF	500Ω	2×V <sub>CC</sub>
4.5V to 5.5V	V <sub>CC</sub>	≤ 3ns	50pF	500Ω	2×V <sub>CC</sub>



## 4.3、AC Testing Waveforms

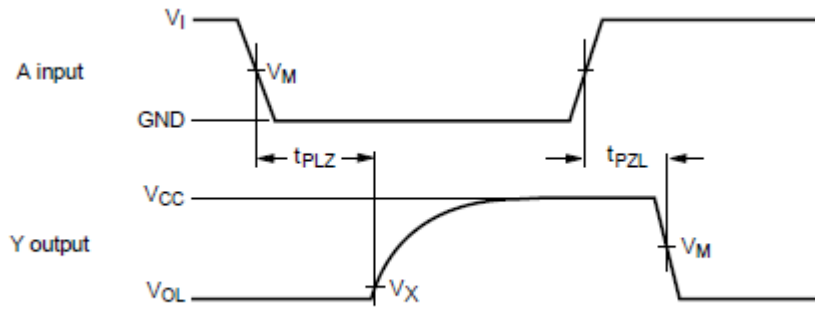

Figure 3. The data input (A) to output (Y) propagation delays

## 4.4、Measurement Points

Supply voltage	Input	Output	
$V_{CC}$	$V_M$	$V_M$	$V_X$
1.65V to 1.95V	$0.5 \times V_{CC}$	$0.5 \times V_{CC}$	$V_{OL} + 0.15V$
2.3V to 2.7V	$0.5 \times V_{CC}$	$0.5 \times V_{CC}$	$V_{OL} + 0.15V$
2.7V	1.5V	1.5V	$V_{OL} + 0.3V$
3.0V to 3.6V	1.5V	1.5V	$V_{OL} + 0.3V$
4.5V to 5.5V	$0.5 \times V_{CC}$	$0.5 \times V_{CC}$	$V_{OL} + 0.3V$



## 5、Package Information

### 5.1、SOT23-6

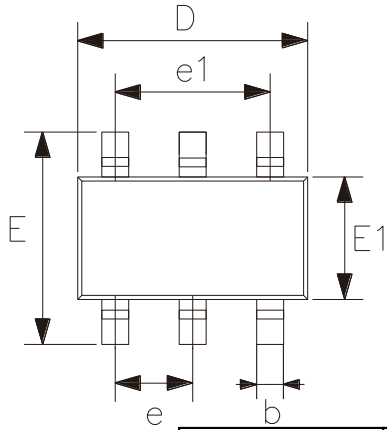
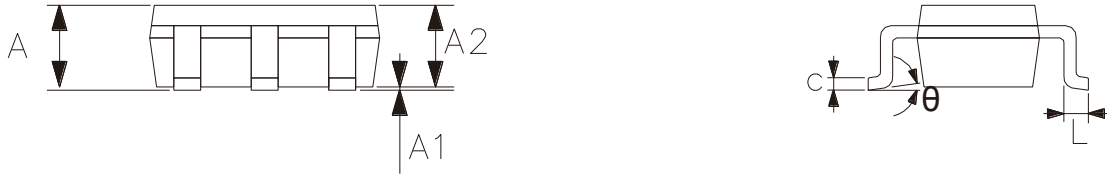

2023/12/A Symbol	Dimensions In Millimeters	
	Min.	Max.
A	—	1.25
A1	0.00	0.12
A2	1.00	1.20
b	0.30	0.50
c	0.10	0.20
D	2.82	3.02
E	2.60	3.00
E1	1.50	1.70
e	0.95	
e1	1.80	2.00
L	0.30	0.60
$\theta$	0°	8°



5.2、SOT363

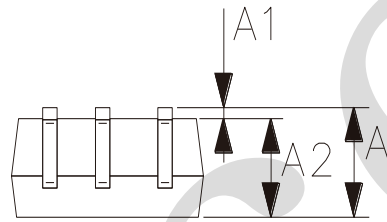
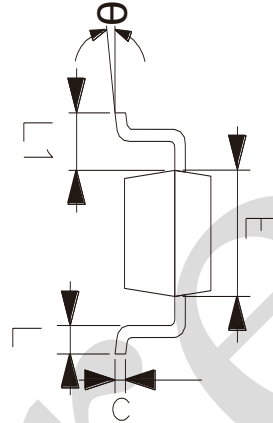
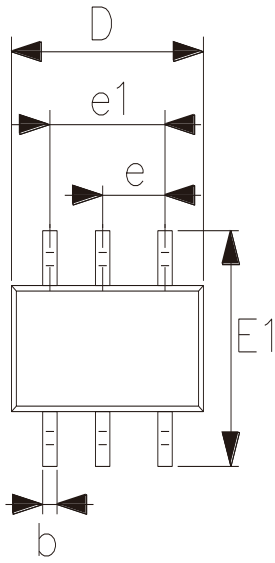

2023/12/A	Dimensions In Millimeters	
Symbol	Min.	Max.
A	0.90	1.10
A1	0.00	0.10
A2	0.90	1.00
b	0.15	0.35
c	0.11	0.175
D	2.00	2.20
E1	2.15	2.45
E	1.15	1.35
e	0.65	
e1	1.20	1.40
L	0.26	0.46
L1	0.525	
$\theta$	0°	8°



## 5.3、XSON6(1\*1.45\*0.55-0.5)

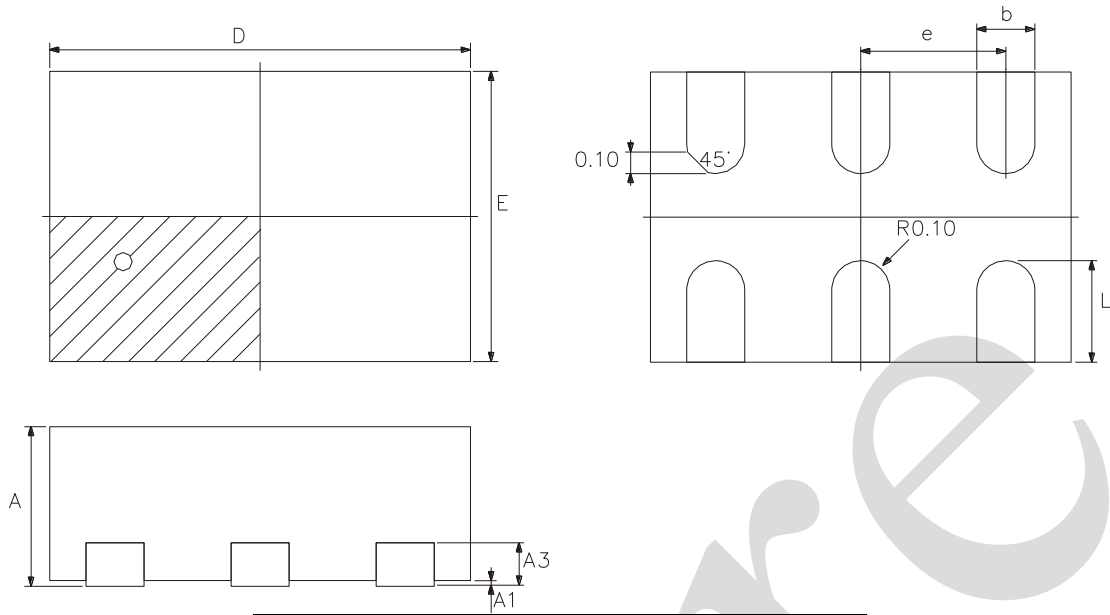

2023/12/A	Dimensions In Millimeters	
	Min	Max
A	0.51	0.60
A1	0.00	0.05
A3	0.15	
b	0.15	0.25
D	1.45	
E	1.00	
e	0.50	
L	0.25	0.45



## 5.4. XSON6(1\*1\*0.45-0.35)

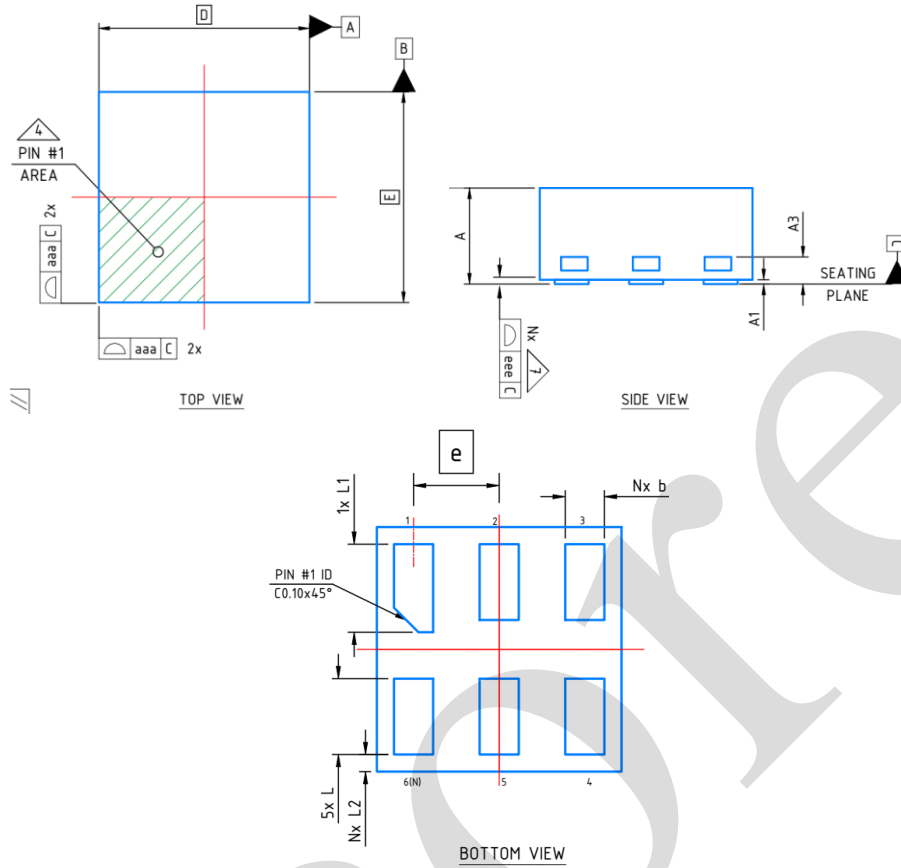

2023/12/A	Dimensions In Millimeters	
Symbol	Min	Max
A	0.41	0.50
A1	0.00	0.05
A3	0.127	
b	0.11	0.21
D	1.00	
E	1.00	
e	0.35	
L	0.26	0.36
L1	0.31	0.41
L2	0.02	0.12



## 6、 Statements And Notes

### 6.1、 The name and content of Hazardous substances or Elements in the product

Part name	Hazardous substances or Elements									
	Lead and lead compounds	Mercury and mercury compounds	Cadmium and cadmium compounds	Hexavalent chromium compounds	Polybrominated biphenyls	Polybrominated biphenyl ethers	Dibutyl phthalate	Butylbenzyl phthalate	Di-2-ethylhexyl phthalate	Diisobutyl phthalate
Lead frame	○	○	○	○	○	○	○	○	○	○
Plastic resin	○	○	○	○	○	○	○	○	○	○
Chip	○	○	○	○	○	○	○	○	○	○
The lead	○	○	○	○	○	○	○	○	○	○
Plastic sheet installed	○	○	○	○	○	○	○	○	○	○
explanation	○: Indicates that the content of hazardous substances or elements in the detection limit of the following the SJ/T11363-2006 standard. ×: Indicates that the content of hazardous substances or elements exceeding the SJ/T11363-2006 Standard limit requirements.									

### 6.2、 Notes

We recommend you to read this chapter carefully before using this product.

The information in this chapter is provided for reference only and i-Core disclaims any express or implied warranties, including but not limited to applicability, special application or non-infringement of third party rights.

This product is not suitable for critical equipment such as life-saving, life-sustaining or safety equipment. It is also not suitable for applications that may result in personal injury, death, or serious property or environmental damage due to product malfunction or failure. I-Core will not be liable for any damages incurred by the customers at their own risk for such applications.

The customer is responsible for conducting all necessary tests i-Core's application to avoid failure in the application or the application of the customer's third party users. I-Core does not accept any liability.

The Company reserves the right to change or improve the information published in this chapter at any time. The information in this chapter are subject to change without notice. We recommend the customer to consult our sales staff before purchasing.

Please obtain related materials form i-Core's regular channels and we are not responsible for its content if it is provided by sources other than our company.

In case of any conflict between the Chinese and English version, the version is subject to the Chinese one.