



AiP74LVC2G32

Dual 2-input Or Gate

Product Specification

Specification Revision History:

Version	Date	Description
2017-05-A1	2017-05	New
2023-04-B1	2023-04	Update the template



Contents

1、 General Description.....	3
2、 Block Diagram And Pin Description	5
2.1、 Block Diagram	5
2.2、 Pin Configurations.....	5
2.3、 Pin Description	6
2.4、 Function Table.....	6
3、 Electrical Parameter	6
3.1、 Absolute Maximum Ratings.....	6
3.2、 Recommended operating conditions	7
3.3、 Electrical Characteristics	7
3.3.1、 DC Characteristics 1	7
3.3.2、 DC Characteristics 2	8
3.3.3、 AC Characteristics 1	9
3.3.4、 AC Characteristics 2	9
4、 Testing Circuit	10
4.1、 AC Testing Circuit	10
4.2、 AC Testing Waveforms.....	10
4.3、 Measurement Points	11
4.4、 Test Data	11
5、 Package Information	12
5.1、 TSSOP8.....	12
5.2、 VSSOP8	13
5.3、 XSON8.....	14
6、 Statements And Notes	15
6.1、 The name and content of Hazardous substances or Elements in the product	15
6.2、 Notes	15



1、General Description

The AiP74LVC2G32 provides a 2-input OR gate function.

Inputs can be driven from either 3.3V or 5V devices. This feature allows the use of these devices as translators in a mixed 3.3V and 5V environment.

This device is fully specified for partial power-down applications using I_{OFF} . The I_{OFF} circuitry disables the output, preventing a damaging backflow current through the device when it is powered down.

Features:

- Wide supply voltage range from 1.65V to 5.5V
- 5V tolerant outputs in the Power-down mode
- $\pm 24\text{mA}$ output drive ($V_{CC}=3.0\text{V}$)
- CMOS low power consumption
- Latch-up performance exceeds 250mA
- Direct interface with TTL levels
- Inputs accept voltages up to 5V
- Specified from -40°C to $+125^{\circ}\text{C}$
- Packaging information: TSSOP8/VSSOP8/XSON8

**Ordering Information:****Tube packing specifications:**

Part number	Packaging form	Marking code	Tube quantity	Boxed tube quantity	Boxed quantity	Notes
AiP74LVC2G32TA8.TB	TSSOP8	BNXX	100 PCS/tube	200 tube/box	20000 PCS/box	Dimensions of plastic enclosure: 3.0mm×3.0mm Pin spacing: 0.65mm

Reel packing specifications:

Part number	Packaging form	Marking code	Reel quantity	Boxed reel quantity	Notes
AiP74LVC2G32TA8.TR	TSSOP8	BNXX	3000 PCS/reel	3000 PCS/box	Dimensions of plastic enclosure: 3.0mm×3.0mm Pin spacing: 0.65mm
AiP74LVC2G32YA8.TR	VSSOP8	BNXX	3000 PCS/reel	3000 PCS/box	Dimensions of plastic enclosure: 2.0mm×2.3mm Pin spacing:0.50mm
AiP74LVC2G32EB8.TR	XSON8	BNXX	5000 PCS/reel	25000 PCS/box	Dimensions of plastic enclosure: 1.35mm×1.0mm Pin spacing:0.35mm

Note 1: "XX" refers to variable content, meaning year and package batch serial number.

Note 2: If the physical information is inconsistent with the ordering information, please refer to the actual product.



2、Block Diagram And Pin Description

2.1、Block Diagram

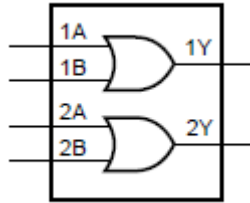

Figure 1. Logic symbol

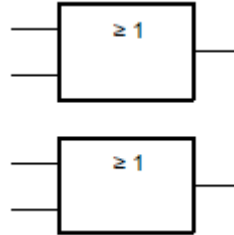

Figure 2. IEC logic symbol

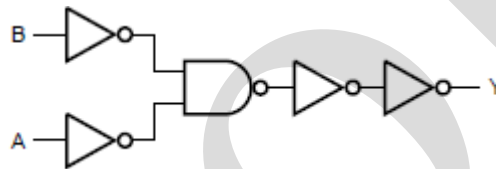
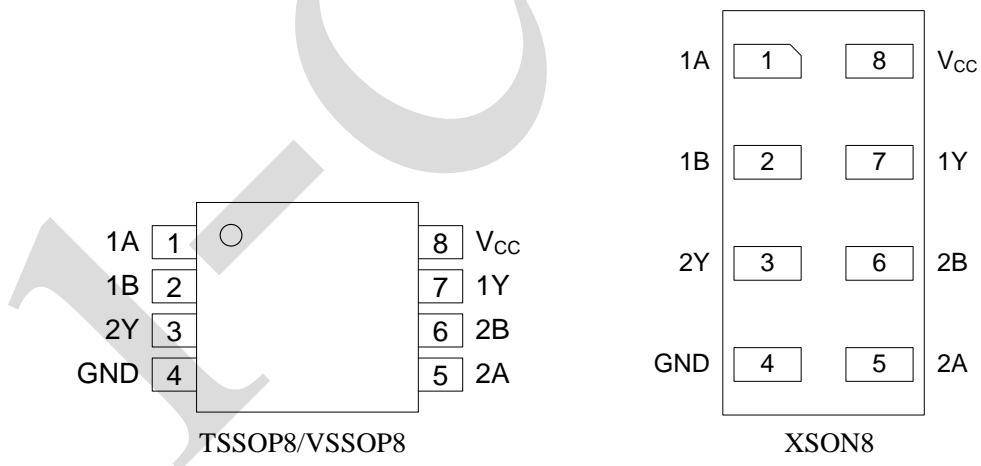

Figure 3. Logic diagram (one gate)

2.2、Pin Configurations





2.3、Pin Description

Pin No.	Pin Name	Description
1	1A	data input
2	1B	data input
3	2Y	data output
4	GND	ground (0V)
5	2A	data input
6	2B	data input
7	1Y	data output
8	V _{CC}	supply voltage

2.4、Function Table

Input		Output
nA	nB	nY
L	L	L
L	H	H
H	L	H
H	H	H

Note: H=HIGH voltage level; L=LOW voltage level.

3、Electrical Parameter

3.1、Absolute Maximum Ratings

(Voltages are referenced to GND(ground=0V), unless otherwise specified.)

Parameter	Symbol	Conditions	Min.	Max.	Unit
supply voltage	V _{CC}	-	-0.5	+6.5	V
input voltage	V _I	-	-0.5	+6.5	V
output voltage	V _O	Active mode	-0.5	V _{CC} +0.5	V
		Power-down mode	-0.5	+6.5	V
input clamping current	I _{IK}	V _I < 0V	-50	-	mA
output clamping current	I _{OK}	V _O > V _{CC} or V _O < 0V	-	±50	mA
output current	I _O	V _O =0V to V _{CC}	-	±50	mA
supply current	I _{CC}	-	-	100	mA
ground current	I _{GND}	-	-100	-	mA
storage temperature	T _{stg}	-	-65	+150	°C
total power dissipation	P _{tot}	-	-	300	mW
Soldering temperature	T _L	10s	260		°C

Note: When V_{CC}=0V (Power-down mode), the output voltage can be 5.5V in normal operation.



3.2、Recommended operating conditions

Parameter	Symbol	Conditions	Min.	Typ.	Max.	Unit
supply voltage	V_{CC}	-	1.65	-	5.5	V
input voltage	V_I	-	0	-	5.5	V
output voltage	V_O	Active mode	0	-	V_{CC}	V
		Power-down mode	0	-	5.5	V
ambient temperature	T_{amb}	-	-40	-	+125	°C
input transition rise and fall rate	$\Delta t/\Delta V$	$V_{CC}=1.65V$ to $2.7V$	-	-	20	ns/V
		$V_{CC}=2.7V$ to $5.5V$	-	-	10	ns/V

3.3、Electrical Characteristics

3.3.1、DC Characteristics 1

($T_{amb}=-40^{\circ}C$ to $+85^{\circ}C$, voltages are referenced to GND (ground=0V), unless otherwise specified.)

Parameter	Symbol	Conditions	Min.	Typ.	Max.	Unit	
HIGH-level input voltage	V_{IH}	$V_{CC}=1.65V$ to $1.95V$	$0.65 \times V_{CC}$	-	-	V	
		$V_{CC}=2.3V$ to $2.7V$	1.7	-	-	V	
		$V_{CC}=2.7V$ to $3.6V$	2.0	-	-	V	
		$V_{CC}=4.5V$ to $5.5V$	$0.7 \times V_{CC}$	-	-	V	
LOW-level input voltage	V_{IL}	$V_{CC}=1.65V$ to $1.95V$	-	-	$0.35 \times V_{CC}$	V	
		$V_{CC}=2.3V$ to $2.7V$	-	-	0.7	V	
		$V_{CC}=2.7V$ to $3.6V$	-	-	0.8	V	
		$V_{CC}=4.5V$ to $5.5V$	-	-	$0.3 \times V_{CC}$	V	
HIGH-level output voltage	V_{OH}	$V_I = V_{IH}$ or V_{IL}	$I_O=-100\mu A$; $V_{CC}=1.65V$ to $5.5V$	$V_{CC}-0.1$	-	-	V
			$I_O=-4mA$; $V_{CC}=1.65V$	1.2	1.53	-	V
			$I_O=-8mA$; $V_{CC}=2.3V$	1.9	2.13	-	V
			$I_O=-12mA$; $V_{CC}=2.7V$	2.2	2.50	-	V
			$I_O=-24mA$; $V_{CC}=3.0V$	2.3	2.60	-	V
			$I_O=-32mA$; $V_{CC}=4.5V$	3.8	4.10	-	V
LOW-level output voltage	V_{OL}	$V_I = V_{IH}$ or V_{IL}	$I_O=100\mu A$; $V_{CC}=1.65V$ to $5.5V$	-	-	0.10	V
			$I_O=4mA$; $V_{CC}=1.65V$	-	0.08	0.45	V
			$I_O=8mA$; $V_{CC}=2.3V$	-	0.14	0.30	V
			$I_O=12mA$; $V_{CC}=2.7V$	-	0.19	0.40	V
			$I_O=24mA$; $V_{CC}=3.0V$	-	0.37	0.55	V
			$I_O=32mA$; $V_{CC}=4.5V$	-	0.43	0.55	V
input leakage current	I_I	$V_I=5.5V$ or GND; $V_{CC}=0V$ to $5.5V$	-	-	± 1	μA	
power-off leakage current	I_{OFF}	V_I or $V_O=5.5V$; $V_{CC}=0V$	-	-	± 2	μA	
supply current	I_{CC}	$V_I=5.5V$ or GND; $I_O=0A$; $V_{CC}=1.65V$ to $5.5V$	-	-	4	μA	
additional	ΔI_{CC}	per pin; $V_I=V_{CC}-0.6V$; $I_O=0A$;	-	-	500	μA	



supply current		$V_{CC}=2.3V$ to $5.5V$				
input capacitance	C_I	-	-	2.5	-	pF

Note: All typical values are measured at $T_{amb}=25^{\circ}C$.

3.3.2、DC Characteristics 2

($T_{amb}=-40^{\circ}C$ to $+125^{\circ}C$, voltages are referenced to GND (ground=0V), unless otherwise specified.)

Parameter	Symbol	Conditions	Min.	Typ.	Max.	Unit	
HIGH-level input voltage	V_{IH}	$V_{CC}=1.65V$ to $1.95V$	$0.65 \times V_{CC}$	-	-	V	
		$V_{CC}=2.3V$ to $2.7V$	1.7	-	-	V	
		$V_{CC}=2.7V$ to $3.6V$	2.0	-	-	V	
		$V_{CC}=4.5V$ to $5.5V$	$0.7 \times V_{CC}$	-	-	V	
LOW-level input voltage	V_{IL}	$V_{CC}=1.65V$ to $1.95V$	-	-	$0.35 \times V_{CC}$	V	
		$V_{CC}=2.3V$ to $2.7V$	-	-	0.7	V	
		$V_{CC}=2.7V$ to $3.6V$	-	-	0.8	V	
		$V_{CC}=4.5V$ to $5.5V$	-	-	$0.3 \times V_{CC}$	V	
HIGH-level output voltage	V_{OH}	$V_I = V_{IH}$ or V_{IL}	$I_O=-100\mu A$; $V_{CC}=1.65V$ to $5.5V$	$V_{CC}-0.1$	-	-	V
			$I_O=-4mA$; $V_{CC}=1.65V$	0.95	-	-	V
			$I_O=-8mA$; $V_{CC}=2.3V$	1.7	-	-	V
			$I_O=-12mA$; $V_{CC}=2.7V$	1.9	-	-	V
			$I_O=-24mA$; $V_{CC}=3.0V$	2.0	-	-	V
			$I_O=-32mA$; $V_{CC}=4.5V$	3.4	-	-	V
LOW-level output voltage	V_{OL}	$V_I = V_{IH}$ or V_{IL}	$I_O=100\mu A$; $V_{CC}=1.65V$ to $5.5V$	-	-	0.10	V
			$I_O=4mA$; $V_{CC}=1.65V$	-	-	0.70	V
			$I_O=8mA$; $V_{CC}=2.3V$	-	-	0.45	V
			$I_O=12mA$; $V_{CC}=2.7V$	-	-	0.60	V
			$I_O=24mA$; $V_{CC}=3.0V$	-	-	0.80	V
			$I_O=32mA$; $V_{CC}=4.5V$	-	-	0.80	V
input leakage current	I_I	$V_I=5.5V$ or GND; $V_{CC}=0V$ to $5.5V$	-	-	± 1	μA	
power-off leakage current	I_{OFF}	V_I or $V_O=5.5V$; $V_{CC}=0V$	-	-	± 2	μA	
supply current	I_{CC}	$V_I=5.5V$ or GND; $I_O=0A$; $V_{CC}=1.65V$ to $5.5V$	-	-	4	μA	
additional supply current	ΔI_{CC}	per pin; $V_I=V_{CC}-0.6V$; $I_O=0A$; $V_{CC}=2.3V$ to $5.5V$	-	-	500	μA	

Note: All typical values are measured at $T_{amb}=25^{\circ}C$.



3.3.3、 AC Characteristics 1

($T_{amb}=-40^{\circ}\text{C}$ to $+85^{\circ}\text{C}$, voltages are referenced to GND (ground=0V), unless otherwise specified.)

Parameter	Symbol	Conditions	Min.	Typ.	Max.	Unit	
nA, nB to nY propagation delay	t_{pd}	see Figure 5	$V_{CC}=1.65\text{V}$ to 1.95V	1.3	3.9	8.8	ns
			$V_{CC}=2.3\text{V}$ to 2.7V	0.8	2.4	4.7	ns
			$V_{CC}=2.7\text{V}$	0.8	2.7	4.8	ns
			$V_{CC}=3.0\text{V}$ to 3.6V	0.9	2.2	4.2	ns
			$V_{CC}=4.5\text{V}$ to 5.5V	0.7	1.7	3.2	ns
Power dissipation capacitance	C_{PD}	per gate; $V_I=\text{GND}$ to V_{CC}	-	14	-	pF	

Note:

[1] Typical values are measured at normal V_{CC} and $T_{amb}=25^{\circ}\text{C}$.

[2] t_{pd} is the same as t_{PLH} and t_{PHL} .

[3] C_{PD} is used to determine the dynamic power dissipation (P_D in uW).

$$P_D=C_{PD}\times V_{CC}^2\times f_i\times N+\sum(C_L\times V_{CC}^2\times f_o)$$
 where:

f_i =input frequency in MHz;

f_o =output frequency in MHz;

C_L =output load capacitance in pF;

V_{CC} =supply voltage in V;

N =number of inputs switching;

$\sum(C_L\times V_{CC}^2\times f_o)$ =sum of outputs.

3.3.4、 AC Characteristics 2

($T_{amb}=-40^{\circ}\text{C}$ to $+125^{\circ}\text{C}$, voltages are referenced to GND (ground=0V), unless otherwise specified.)

Parameter	Symbol	Conditions	Min.	Typ.	Max.	Unit	
nA, nB to nY propagation delay	t_{pd}	see Figure 5	$V_{CC}=1.65\text{V}$ to 1.95V	1.3	-	11.0	ns
			$V_{CC}=2.3\text{V}$ to 2.7V	0.8	-	5.9	ns
			$V_{CC}=2.7\text{V}$	0.8	-	6.0	ns
			$V_{CC}=3.0\text{V}$ to 3.6V	0.9	-	5.3	ns
			$V_{CC}=4.5\text{V}$ to 5.5V	0.7	-	4.0	ns

Note:

[1] Typical values are measured at normal V_{CC} and $T_{amb}=25^{\circ}\text{C}$.

[2] t_{pd} is the same as t_{PLH} and t_{PHL} .



4、Testing Circuit

4.1、AC Testing Circuit

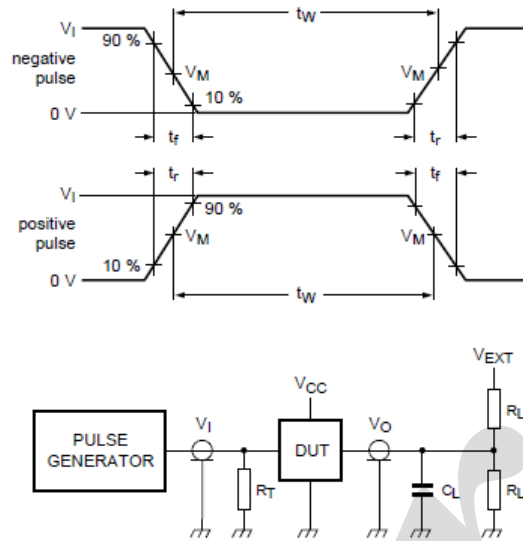

Figure 4. Test circuit for measuring switching times

Definitions for test circuit:

R_L =Load resistance.

C_L =Load capacitance including jig and probe capacitance.

R_T =Termination resistance; should be equal to the output impedance Z_o of the pulse generator.

V_{EXT} =External voltage for measuring switching times.

4.2、AC Testing Waveforms

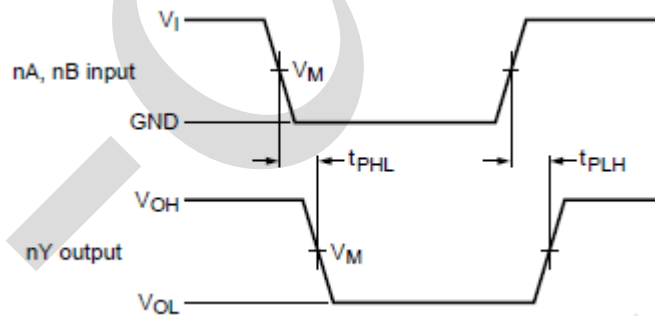

Figure 5. The input (nA, nB) to output (nY) propagation delays



4.3、Measurement Points

Supply voltage	Input	Output
V_{CC}	V_M	V_M
1.65V to 1.95V	$0.5 \times V_{CC}$	$0.5 \times V_{CC}$
2.3V to 2.7V	$0.5 \times V_{CC}$	$0.5 \times V_{CC}$
2.7V	1.5V	1.5V
3.0V to 3.6V	1.5V	1.5V
4.5V to 5.5V	$0.5 \times V_{CC}$	$0.5 \times V_{CC}$

4.4、Test Data

Supply voltage	Input		Load		V_{EXT}
	V_I	$t_r = t_f$	C_L	R_L	t_{PLH}, t_{PHL}
1.65V to 1.95V	V_{CC}	$\leq 2.0ns$	30pF	1k Ω	open
2.3V to 2.7V	V_{CC}	$\leq 2.0ns$	30pF	500 Ω	open
2.7V	2.7V	$\leq 2.5ns$	50pF	500 Ω	open
3.0V to 3.6V	2.7V	$\leq 2.5ns$	50pF	500 Ω	open
4.5V to 5.5V	V_{CC}	$\leq 2.5ns$	50pF	500 Ω	open



5、Package Information

5.1、TSSOP8

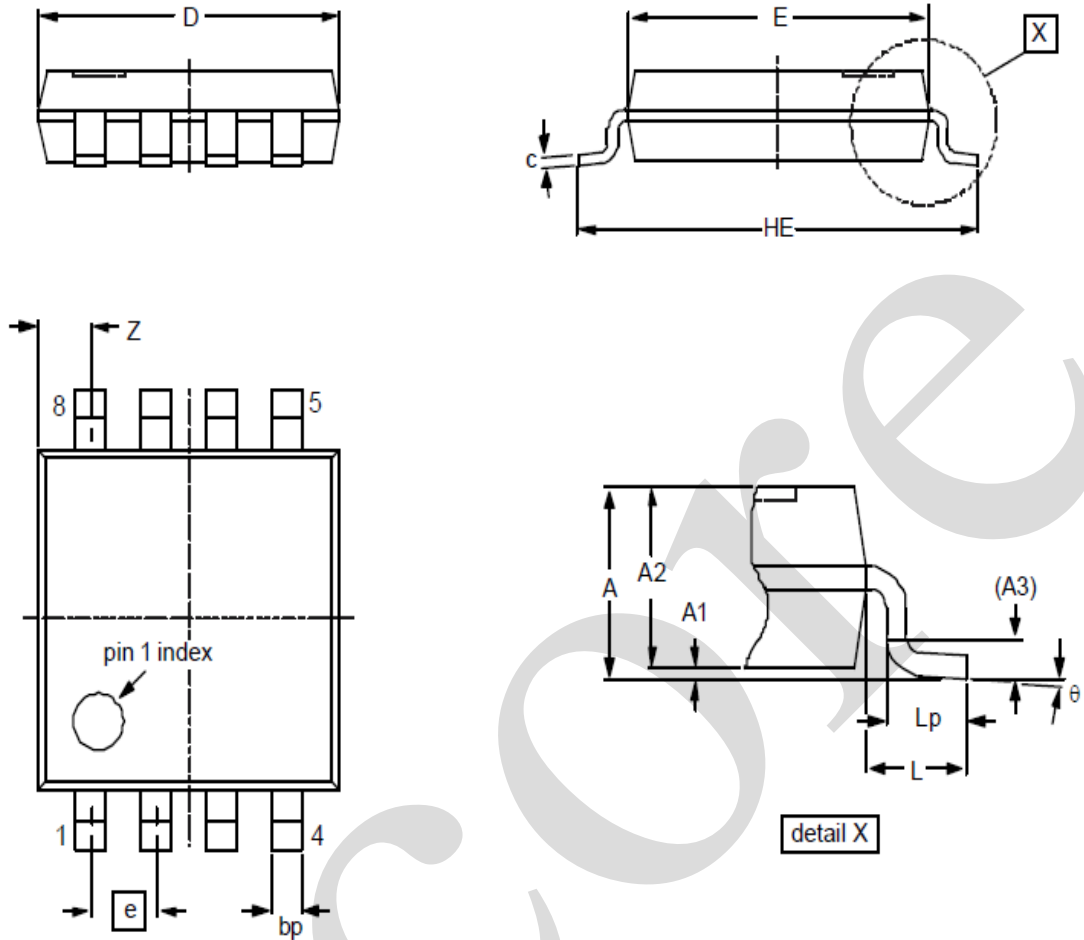

Symbol	Dimensions (mm)	
	Min.	Max.
A	-	1.10
A1	0	0.15
A2	0.75	0.95
A3	0.25	
bp	0.22	0.38
c	0.08	0.18
D	2.90	3.10
E	2.90	3.10
HE	3.90	4.10
L	0.50	
Lp	0.33	0.47
e	0.65	
Z	0.35	0.70
θ	0°	8°



5.2、VSSOP8

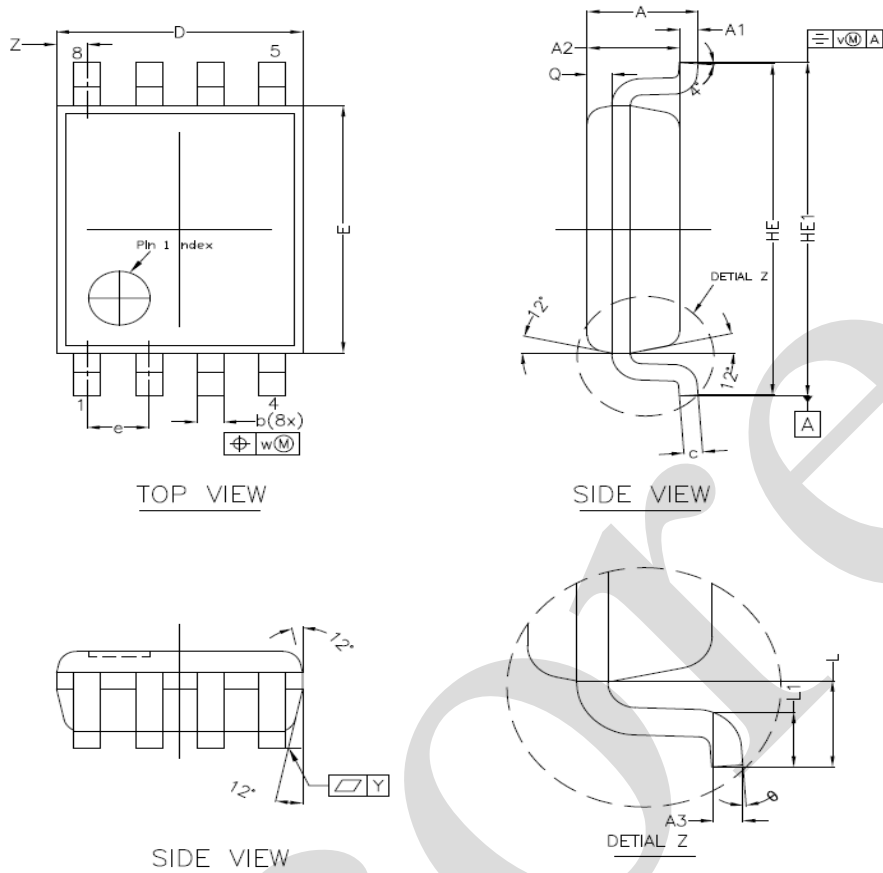

NOTES
1.0 COP
DIE ATTA
2.0 D E

Symbol	Dimensions (mm)	
	Min.	Max.
A	-	1.00
A1	0.00	0.15
A2	0.60	0.85
A3	0.12	
Q	0.19	0.21
b	0.17	0.27
c	0.08	0.23
D	1.90	2.10
E	2.20	2.40
HE	3.00	3.20
e	0.50	
L	0.40	
L1	0.15	0.40
Y	0.10	
Z	0.10	0.40
θ	0°	8°



5.3、XSON8

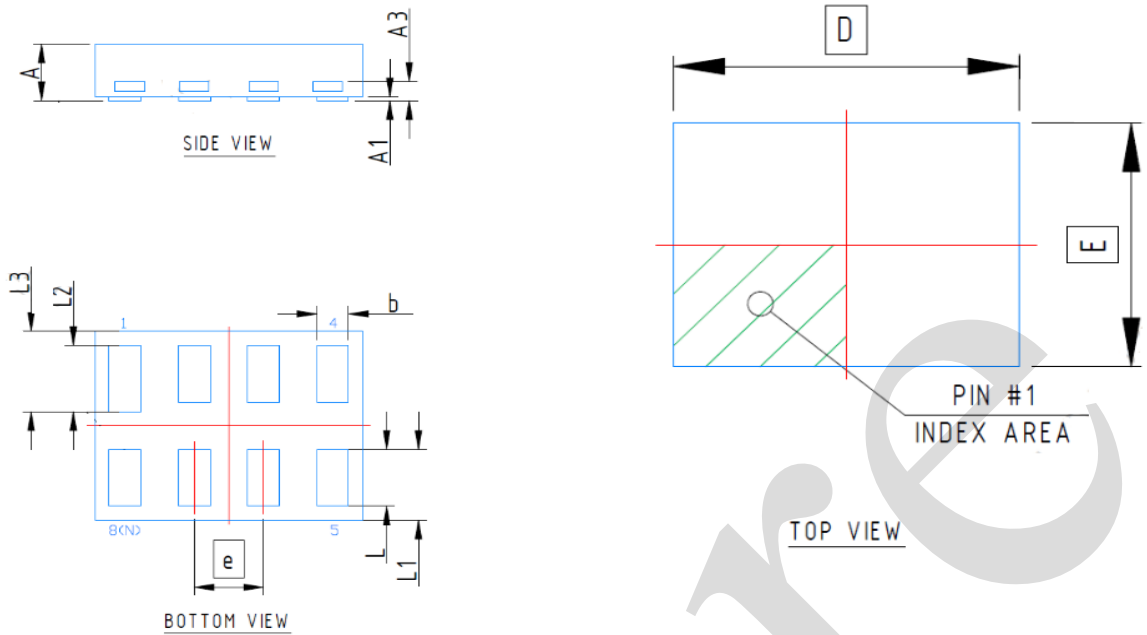

Symbol	Dimensions (mm)	
	Min.	Max.
A	0.28	0.32
A1	0.00	0.05
A3	0.10	
b	0.11	0.21
D	1.35	
E	1.00	
e	0.35	
L	0.25	0.35
L1	0.275	0.475
L2	0.30	0.40
L3	0.325	0.525



6、 Statements And Notes

6.1、 The name and content of Hazardous substances or Elements in the product

Part name	Hazardous substances or Elements									
	Lead and lead compounds	Mercury and mercury compounds	Cadmium and cadmium compounds	Hexavalent chromium compounds	Polybrominated biphenyls	Polybrominated biphenyl ethers	Dibutyl phthalate	Butylbenzyl phthalate	Di-2-ethylhexyl phthalate	Diisobutyl phthalate
Lead frame	○	○	○	○	○	○	○	○	○	○
Plastic resin	○	○	○	○	○	○	○	○	○	○
Chip	○	○	○	○	○	○	○	○	○	○
The lead	○	○	○	○	○	○	○	○	○	○
Plastic sheet installed	○	○	○	○	○	○	○	○	○	○
explanation	○: Indicates that the content of hazardous substances or elements in the detection limit of the following the SJ/T11363-2006 standard. ×: Indicates that the content of hazardous substances or elements exceeding the SJ/T11363-2006 Standard limit requirements.									

6.2、 Notes

We recommend you to read this chapter carefully before using this product.

The information in this chapter is provided for reference only and i-Core disclaims any express or implied warranties, including but not limited to applicability, special application or non-infringement of third party rights.

This product is not suitable for critical equipment such as life-saving, life-sustaining or safety equipment. It is also not suitable for applications that may result in personal injury, death, or serious property or environmental damage due to product malfunction or failure. I-Core will not be liable for any damages incurred by the customers at their own risk for such applications.

The customer is responsible for conducting all necessary tests i-Core's application to avoid failure in the application or the application of the customer's third party users. I-Core does not accept any liability.

The Company reserves the right to change or improve the information published in this chapter at any time. The information in this chapter are subject to change without notice. We recommend the customer to consult our sales staff before purchasing.

Please obtain related materials form i-Core's regular channels and we are not responsible for its content if it is provided by sources other than our company.

In case of any conflict between the Chinese and English version, the version is subject to the Chinese one.