



AiP74LV32

Quad 2-input Or Gate

Product Specification

Specification Revision History:

Version	Date	Description
2017-05-A1	2017-05	New
2023-04-B1	2023-04	Update the template



Contents

1、 General Description.....	3
2、 Block Diagram And Pin Description	5
2.1、 Block Diagram	5
2.2、 Pin Configurations.....	6
2.3、 Pin Description	6
2.4、 Function Table.....	6
3、 Electrical Parameter	7
3.1、 Absolute Maximum Ratings.....	7
3.2、 Recommended Operating Conditions	7
3.3、 Electrical Characteristics	8
3.3.1、 DC Characteristics 1	8
3.3.2、 DC Characteristics 2	9
3.3.3、 AC Characteristics 1	10
3.3.4、 AC Characteristics 2	10
4、 Testing Circuit	11
4.1、 AC Testing Circuit	11
4.2、 AC Testing Waveforms.....	11
4.3、 Measurement Points	11
4.4、 Test Data	11
5、 Package Information	12
5.1、 DIP14	12
5.2、 SOP14	13
5.3、 TSSOP14.....	14
6、 Statements And Notes	15
6.1、 The name and content of Hazardous substances or Elements in the product	15
6.2、 Notes	15



1、 General Description

The AiP74LV32 is a low-voltage CMOS device that is pin and function compatible with AiP74HC32 and AiP74HCT32.

The AiP74LV32 provides a quad 2-input OR function.

Features:

- Operating voltage: 1.0V to 5.5V
- 5.5V tolerant inputs/outputs
- Power-down mode
- Specified from -40°C to +125°C
- Packaging information: DIP14/SOP14/TSSOP14

**Ordering Information:****Tube packing specifications:**

Part number	Packaging form	Marking code	Tube quantity	Boxed tube quantity	Boxed quantity	Notes
AiP74LV32DA14.TB	DIP14	74LV32	25 PCS/tube	40 tube/box	1000 PCS/box	Dimensions of plastic enclosure: 19.0mm×6.4mm Pin spacing: 2.54mm
AiP74LV32SA14.TB	SOP14	74LV32	50 PCS/tube	200 tube/box	10000 PCS/box	Dimensions of plastic enclosure: 8.7mm×3.9mm Pin spacing: 1.27mm
AiP74LV32TA14.TB	TSSOP14	74LV32	96 PCS/tube	200 tube/box	19200 PCS/box	Dimensions of plastic enclosure: 5.0mm×4.4mm Pin spacing: 0.65mm

Reel packing specifications:

Part number	Packaging form	Marking code	Reel quantity	Boxed reel quantity	Notes
AiP74LV32SA14.TR	SOP14	74LV32	4000 PCS/reel	8000 PCS/box	Dimensions of plastic enclosure: 8.7mm×3.9mm Pin spacing: 1.27mm
AiP74LV32TA14.TR	TSSOP14	74LV32	5000 PCS/reel	10000 PCS/box	Dimensions of plastic enclosure: 5.0mm×4.4mm Pin spacing: 0.65mm

Note: If the physical information is inconsistent with the ordering information, please refer to the actual product.



2、Block Diagram And Pin Description

2.1、Block Diagram

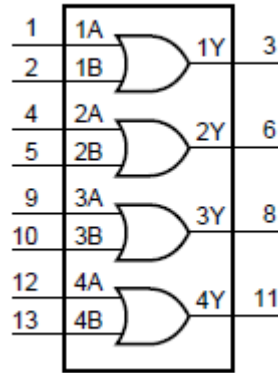

Figure 1. Logic symbol

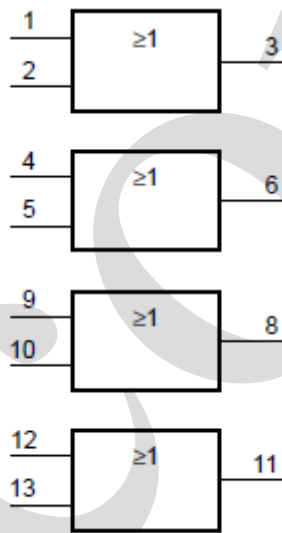

Figure 2. IEC logic symbol

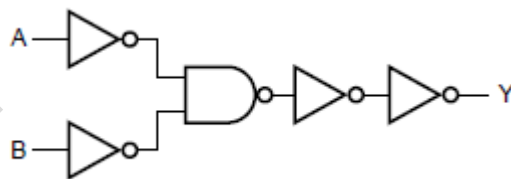
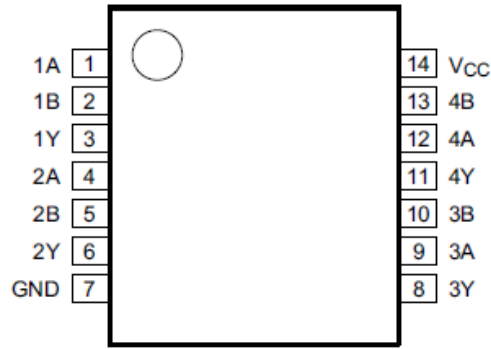

Figure 3. Logic diagram (one gate)



2.2、Pin Configurations



2.3、Pin Description

Pin No.	Pin Name	Description
1	1A	data input
2	1B	data input
3	1Y	data output
4	2A	data input
5	2B	data input
6	2Y	data output
7	GND	ground (0V)
8	3Y	data output
9	3A	data input
10	3B	data input
11	4Y	data output
12	4A	data input
13	4B	data input
14	V _{CC}	supply voltage

2.4、Function Table

Input		Output
nA	nB	nY
H	X	H
X	H	H
L	L	L

Note: H=HIGH voltage level; L=LOW voltage level; X=don't care.



3、Electrical Parameter

3.1、Absolute Maximum Ratings

(Voltages are referenced to GND(ground=0V), unless otherwise specified.)

Parameter	Symbol	Conditions	Min.	Max.	Unit
supply voltage	V_{CC}	-	-0.5	+7.0	V
input clamping current	I_{IK}	$V_I < -0.5V$ or $V_I > V_{CC}+0.5V$	-	± 20	mA
output clamping current	I_{OK}	$V_O < -0.5V$ or $V_O > V_{CC}+0.5V$	-	± 50	mA
output current	I_O	$V_O = -0.5V$ to $(V_{CC}+0.5V)$	-	± 25	mA
supply current	I_{CC}	-	-	50	mA
ground current	I_{GND}	-	-50	-	mA
storage temperature	T_{stg}	-	-65	+150	°C
total power dissipation	P_{tot}	-	-	500	mW
Soldering temperature	T_L	10s	DIP		°C
			SOP/TSSOP		
			245		
			260		

3.2、Recommended Operating Conditions

Parameter	Symbol	Conditions	Min.	Typ.	Max.	Unit
supply voltage	V_{CC}	-	1.0	3.3	5.5	V
input voltage	V_I	-	0	-	V_{CC}	V
output voltage	V_O	-	0	-	V_{CC}	V
ambient temperature	T_{amb}	-	-40	-	+125	°C
input transition rise and fall rate	$\Delta t/\Delta V$	$V_{CC}=1.0V$ to $2.0V$	-	-	500	ns/V
		$V_{CC}=2.0V$ to $2.7V$	-	-	200	ns/V
		$V_{CC}=2.7V$ to $3.6V$	-	-	100	ns/V
		$V_{CC}=3.6V$ to $5.5V$	-	-	50	ns/V

Note: The static characteristics are guaranteed from $V_{CC}=1.2V$ to $V_{CC}=5.5V$, but LV devices are guaranteed to function down to $V_{CC}=1.0V$ (with input levels GND or V_{CC}).



3.3、Electrical Characteristics

3.3.1、DC Characteristics 1

($T_{amb} = -40^{\circ}\text{C}$ to $+85^{\circ}\text{C}$, voltages are referenced to GND (ground=0V), unless otherwise specified.)

Parameter	Symbol	Conditions	Min.	Typ.	Max.	Unit	
HIGH-level input voltage	V_{IH}	$V_{CC}=1.2\text{V}$	V_{CC}	0.6	-	V	
		$V_{CC}=2.0\text{V}$	1.4	-	-	V	
		$V_{CC}=2.7\text{V}$ to 3.6V	2.0	-	-	V	
		$V_{CC}=4.5\text{V}$ to 5.5V	$0.7 \times V_{CC}$	-	-	V	
LOW-level input voltage	V_{IL}	$V_{CC}=1.2\text{V}$	-	0.4	GND	V	
		$V_{CC}=2.0\text{V}$	-	-	0.6	V	
		$V_{CC}=2.7\text{V}$ to 3.6V	-	-	0.8	V	
		$V_{CC}=4.5\text{V}$ to 5.5V	-	-	$0.3 \times V_{CC}$	V	
HIGH-level output voltage	V_{OH}	$V_I = V_{IH}$ or V_{IL}	$I_O = -100\mu\text{A}; V_{CC} = 1.2\text{V}$	-	1.2	-	V
			$I_O = -100\mu\text{A}; V_{CC} = 2.0\text{V}$	1.8	2.0	-	V
			$I_O = -100\mu\text{A}; V_{CC} = 2.7\text{V}$	2.5	2.7	-	V
			$I_O = -100\mu\text{A}; V_{CC} = 3.0\text{V}$	2.8	3.0	-	V
			$I_O = -100\mu\text{A}; V_{CC} = 4.5\text{V}$	4.3	4.5	-	V
			$I_O = -6\text{mA}; V_{CC} = 3.0\text{V}$	2.4	2.82	-	V
			$I_O = -12\text{mA}; V_{CC} = 4.5\text{V}$	3.6	4.2	-	V
LOW-level output voltage	V_{OL}	$V_I = V_{IH}$ or V_{IL}	$I_O = 100\mu\text{A}; V_{CC} = 1.2\text{V}$	-	0	-	V
			$I_O = 100\mu\text{A}; V_{CC} = 2.0\text{V}$	-	0	0.2	V
			$I_O = 100\mu\text{A}; V_{CC} = 2.7\text{V}$	-	0	0.2	V
			$I_O = 100\mu\text{A}; V_{CC} = 3.0\text{V}$	-	0	0.2	V
			$I_O = 100\mu\text{A}; V_{CC} = 4.5\text{V}$	-	0	0.2	V
			$I_O = 6\text{mA}; V_{CC} = 3.0\text{V}$	-	0.25	0.40	V
			$I_O = 12\text{mA}; V_{CC} = 4.5\text{V}$	-	0.35	0.55	V
input leakage current	I_I	$V_I = V_{CC}$ or GND; $V_{CC} = 5.5\text{V}$	-	-	1.0	μA	
supply current	I_{CC}	$V_I = V_{CC}$ or GND; $I_O = 0\text{A}$; $V_{CC} = 5.5\text{V}$	-	-	20	μA	
additional supply current	ΔI_{CC}	per input; $V_I = V_{CC} - 0.6\text{V}$; $V_{CC} = 2.7\text{V}$ to 3.6V	-	-	500	μA	
input capacitance	C_I	-	-	3.5	-	pF	

Note: All typical values are measured at $T_{amb} = 25^{\circ}\text{C}$



3.3.2、DC Characteristics 2

($T_{amb}=-40^{\circ}\text{C}$ to $+125^{\circ}\text{C}$, voltages are referenced to GND (ground=0V), unless otherwise specified.)

Parameter	Symbol	Conditions	Min.	Typ.	Max.	Unit	
HIGH-level input voltage	V_{IH}	$V_{CC}=1.2\text{V}$	V_{CC}	0.6	-	V	
		$V_{CC}=2.0\text{V}$	1.4	-	-	V	
		$V_{CC}=2.7\text{V}$ to 3.6V	2.0	-	-	V	
		$V_{CC}=4.5\text{V}$ to 5.5V	$0.7 \times V_{CC}$	-	-	V	
LOW-level input voltage	V_{IL}	$V_{CC}=1.2\text{V}$	-	0.4	GND	V	
		$V_{CC}=2.0\text{V}$	-	-	0.6	V	
		$V_{CC}=2.7\text{V}$ to 3.6V	-	-	0.8	V	
		$V_{CC}=4.5\text{V}$ to 5.5V	-	-	$0.3 \times V_{CC}$	V	
HIGH-level output voltage	V_{OH}	$V_I = V_{IH}$ or V_{IL}	$I_O=-100\mu\text{A}; V_{CC}=2.0\text{V}$	1.8	-	-	V
			$I_O=-100\mu\text{A}; V_{CC}=2.7\text{V}$	2.5	-	-	V
			$I_O=-100\mu\text{A}; V_{CC}=3.0\text{V}$	2.8	-	-	V
			$I_O=-100\mu\text{A}; V_{CC}=4.5\text{V}$	4.3	-	-	V
			$I_O=-6\text{mA}; V_{CC}=3.0\text{V}$	2.2	-	-	V
			$I_O=-12\text{mA}; V_{CC}=4.5\text{V}$	3.5	-	-	V
LOW-level output voltage	V_{OL}	$V_I = V_{IH}$ or V_{IL}	$I_O=100\mu\text{A}; V_{CC}=2.0\text{V}$	-	-	0.2	V
			$I_O=100\mu\text{A}; V_{CC}=2.7\text{V}$	-	-	0.2	V
			$I_O=100\mu\text{A}; V_{CC}=3.0\text{V}$	-	-	0.2	V
			$I_O=100\mu\text{A}; V_{CC}=4.5\text{V}$	-	-	0.2	V
			$I_O=6\text{mA}; V_{CC}=3.0\text{V}$	-	-	0.50	V
			$I_O=12\text{mA}; V_{CC}=4.5\text{V}$	-	-	0.65	V
input leakage current	I_I	$V_I=V_{CC}$ or GND; $V_{CC}=5.5\text{V}$	-	-	1.0	μA	
supply current	I_{CC}	$V_I=V_{CC}$ or GND; $I_O=0\text{A}$; $V_{CC}=5.5\text{V}$	-	-	40	μA	
additional supply current	ΔI_{CC}	per input; $V_I=V_{CC}-0.6\text{V}$; $V_{CC}=2.7\text{V}$ to 3.6V	-	-	850	μA	

Note: All typical values are measured at $T_{amb}=25^{\circ}\text{C}$



3.3.3、AC Characteristics 1

($T_{amb}=-40^{\circ}\text{C}$ to $+85^{\circ}\text{C}$, voltages are referenced to GND (ground=0V), unless otherwise specified.)

Parameter	Symbol	Conditions	Min.	Typ.	Max.	Unit	
nA, nB to nY; propagation delay	t_{pd}	see Figure 5	$V_{CC}=1.2\text{V}$	-	40	-	ns
			$V_{CC}=2.0\text{V}$	-	14	22	ns
			$V_{CC}=2.7\text{V}$	-	10	16	ns
			$V_{CC}=3.0\text{V}$ to 3.6V ; $C_L=15\text{pF}$	-	6.0	-	ns
			$V_{CC}=3.0\text{V}$ to 3.6V	-	8.0	13	ns
		$V_{CC}=4.5\text{V}$ to 5.5V	-	-	10	ns	
Power dissipation capacitance	C_{PD}	$C_L=50\text{pF}$; $f_i=1\text{MHz}$; $V_I=\text{GND}$ to V_{CC}	-	16	-	pF	

Note:

[1] Typical values are measured at $T_{amb}=25^{\circ}\text{C}$.

[2] t_{pd} is the same as t_{PLH} and t_{PHL} .

[3] Typical values are measured at nominal supply voltage ($V_{CC}=3.3\text{V}$).

[4] C_{PD} is used to determine the dynamic power dissipation (P_D in uW).

$$P_D=C_{PD}\times V_{CC}^2\times f_i\times N+\sum(C_L\times V_{CC}^2\times f_o)$$
 where:

f_i =input frequency in MHz;

f_o =output frequency in MHz;

C_L =output load capacitance in pF;

V_{CC} =supply voltage in V;

N =number of inputs switching;

$\sum(C_L\times V_{CC}^2\times f_o)$ =sum of outputs.

3.3.4、AC Characteristics 2

($T_{amb}=-40^{\circ}\text{C}$ to $+125^{\circ}\text{C}$, voltages are referenced to GND (ground=0V), unless otherwise specified.)

Parameter	Symbol	Conditions	Min.	Typ.	Max.	Unit	
nA, nB to nY; propagation delay	t_{pd}	see Figure 5	$V_{CC}=2.0\text{V}$	-	-	28	ns
			$V_{CC}=2.7\text{V}$	-	-	20	ns
			$V_{CC}=3.0\text{V}$ to 3.6V	-	-	16	ns
			$V_{CC}=4.5\text{V}$ to 5.5V	-	-	13	ns

Note:

[1] Typical values are measured at $T_{amb}=25^{\circ}\text{C}$.

[2] t_{pd} is the same as t_{PLH} and t_{PHL} .

[3] Typical values are measured at nominal supply voltage ($V_{CC}=3.3\text{V}$).



4、 Testing Circuit

4.1、 AC Testing Circuit

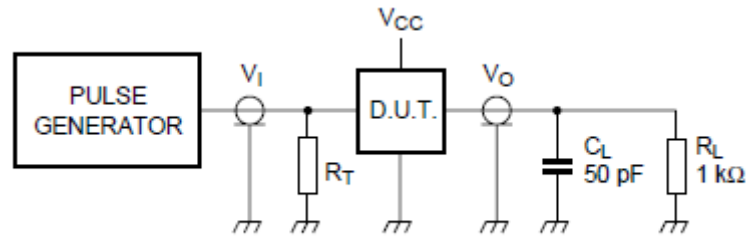

Figure 4. Test circuit for switching times

Definitions for test circuit:

R_L =Load resistance.

C_L =Load capacitance including jig and probe capacitance.

R_T =Termination resistance should be equal to the output impedance Z_o of the pulse generator.

4.2、 AC Testing Waveforms

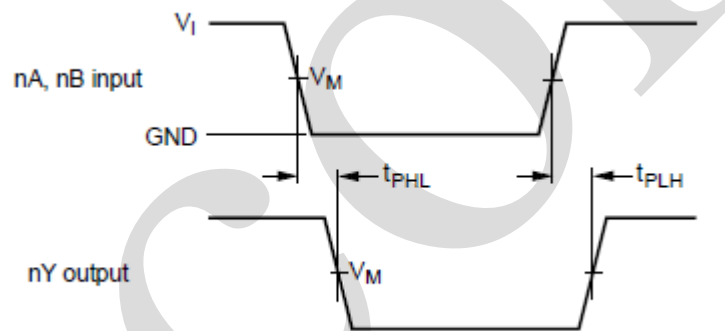

Figure 5. The input (nA, nB) to output (nY) propagation delays

4.3、 Measurement Points

Supply voltage	Input	Output
V_{CC}	V_M	V_M
<2.7V	$0.5 \times V_{CC}$	$0.5 \times V_{CC}$
2.7V to 3.6V	1.5V	1.5V
$\geq 4.5V$	$0.5 \times V_{CC}$	$0.5 \times V_{CC}$

4.4、 Test Data

Supply voltage	Input	
V_{CC}	V_I	t_r, t_f
<2.7V	V_{CC}	$\leq 2.5ns$
2.7V to 3.6V	2.7V	$\leq 2.5ns$
$\geq 4.5V$	V_{CC}	$\leq 2.5ns$



5、Package Information

5.1、DIP14

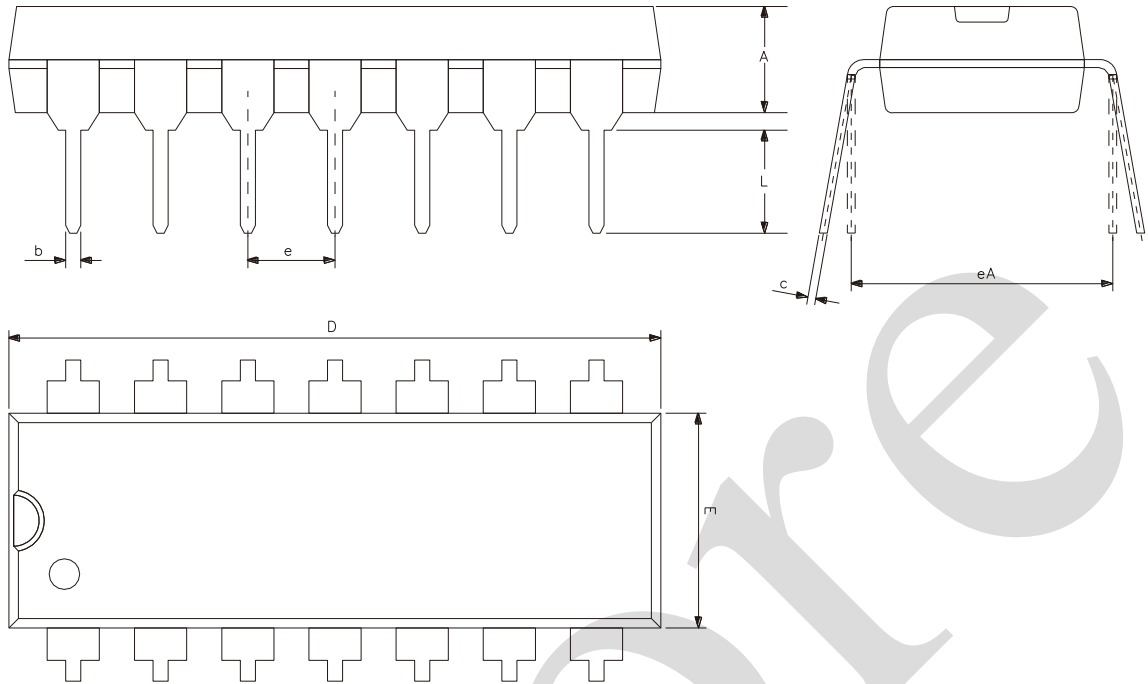

Symbol	Dimensions (mm)	
	Min.	Max.
A	3.05	3.60
b	0.33	0.56
c	0.20	0.36
D	18.80	19.40
E	6.20	6.60
e	2.54	
eA	7.62	10.90
L	2.92	-



5.2、SOP14

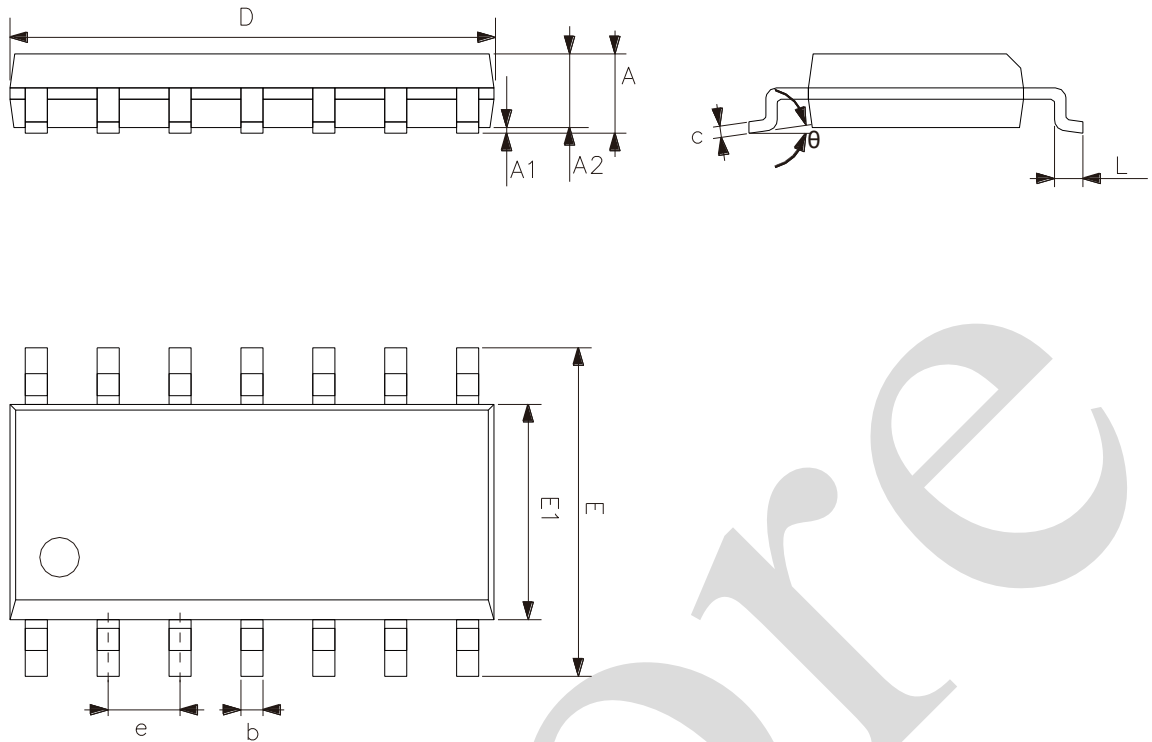

Symbol	Dimensions (mm)	
	Min.	Max.
A	1.50	1.75
A1	0.05	0.25
A2	1.30	-
b	0.33	0.50
c	0.19	0.25
D	8.43	8.76
E	5.80	6.25
E1	3.75	4.00
e	1.27	
L	0.40	0.89
θ	0°	8°



5.3、TSSOP14

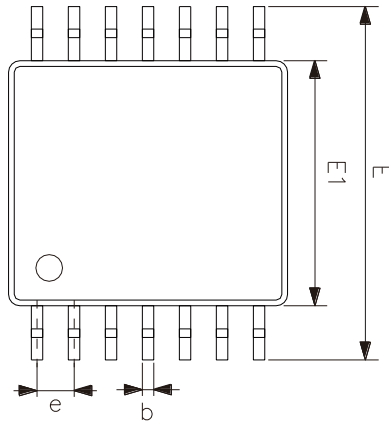
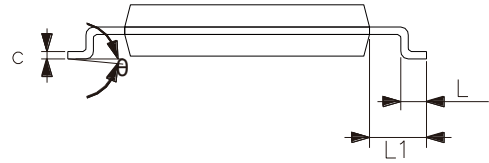
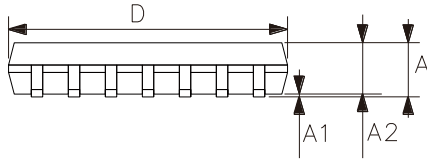

Symbol	Dimensions (mm)	
	Min.	Max.
A	-	1.20
A1	0.05	0.15
A2	0.80	1.05
b	0.19	0.30
c	0.09	0.20
D	4.90	5.10
E1	4.30	4.50
E	6.20	6.60
e	0.65	
L	0.45	0.75
L1	1.00	
θ	0°	8°



6、 Statements And Notes

6.1、 The name and content of Hazardous substances or Elements in the product

Part name	Hazardous substances or Elements									
	Lead and lead compounds	Mercury and mercury compounds	Cadmium and cadmium compounds	Hexavalent chromium compounds	Polybrominated biphenyls	Polybrominated biphenyl ethers	Dibutyl phthalate	Butylbenzyl phthalate	Di-2-ethylhexyl phthalate	Diisobutyl phthalate
Lead frame	○	○	○	○	○	○	○	○	○	○
Plastic resin	○	○	○	○	○	○	○	○	○	○
Chip	○	○	○	○	○	○	○	○	○	○
The lead	○	○	○	○	○	○	○	○	○	○
Plastic sheet installed	○	○	○	○	○	○	○	○	○	○
explanation	○: Indicates that the content of hazardous substances or elements in the detection limit of the following the SJ/T11363-2006 standard. ×: Indicates that the content of hazardous substances or elements exceeding the SJ/T11363-2006 Standard limit requirements.									

6.2、 Notes

We Recommend you to read this chapter carefully before using this product.

The information in this chapter is provided for reference only and i-Core disclaims any express or implied warranties, including but not limited to applicability, special application or non-infringement of third party rights.

This product is not suitable for critical equipment such as life-saving, life-sustaining or safety equipment. It is also not suitable for applications that may result in personal injury, death, or serious property or environmental damage due to product malfunction or failure. I-Core will not be liable for any damages incurred by the customers at their own risk for such applications.

The customer is responsible for conducting all necessary tests i-Core's application to avoid failure in the application or the application of the customer's third party users. I-Core does not accept any liability.

The Company reserves the right to change or improve the information published in this chapter at any time. The information in this chapter are subject to change without notice. We recommend the customer to consult our sales staff before purchasing.

Please obtain related materials form i-Core's regular channels and we are not responsible for its content if it is provided by sources other than our company.

In case of any conflict between the Chinese and English version, the version is subject to the Chinese one.