



AiP74LVC138

3-to-8 Line Decoder/Demultiplexer; Inverting

Product Specification

Specification Revision History:

Version	Date	Description
2017-05-A1	2017-05	New
2023-04-B1	2023-04	Update the template
2025-12-B2	2025-12	Modify the supply voltage range; add the parameters at the condition of $V_{CC}=4.5V$ to $5.5V$; add ESD



Contents

1、 General Description.....	3
2、 Block Diagram And Pin Description	5
2.1、 Block Diagram	5
2.2、 Pin Configurations.....	6
2.3、 Pin Description	6
2.4、 Function Table.....	7
3、 Electrical Parameter	7
3.1、 Absolute Maximum Ratings.....	7
3.2、 Recommended Operating Conditions.....	8
3.3、 Electrical Characteristics	8
3.3.1、 DC Characteristics 1	8
3.3.2、 DC Characteristics 2	9
3.3.3、 AC Characteristics 1	10
3.3.4、 AC Characteristics 2	11
4、 Testing Circuit	12
4.1、 AC Testing Circuit	12
4.2、 AC Testing Waveforms.....	12
4.3、 Measurement Points	13
4.4、 Test Data	13
5、 Package Information	14
5.1、 DIP16	14
5.2、 SOP16	15
5.3、 TSSOP16.....	16
5.4、 DHVQFN16	17
6、 Statements And Notes	18
6.1、 The name and content of Hazardous substances or Elements in the product	18
6.2、 Notes	18



1、 General Description

The AiP74LVC138 is a 3-to-8 line decoder/demultiplexer. It accepts three binary weighted address inputs (A0, A1 and A2) and, when enabled, provides eight mutually exclusive outputs ($\bar{Y}0$ to $\bar{Y}7$) that are LOW when selected.

There are three enable inputs: two active LOW ($\bar{E}1$ and $\bar{E}2$) and one active HIGH (E3). Every output will be HIGH unless $\bar{E}1$ and $\bar{E}2$ are LOW and E3 is HIGH.

This multiple enable function allows easy parallel expansion of the device to a 1-of-32 (5 lines to 32 lines) decoder with just four AiP74LVC138 devices and one inverter. The AiP74LVC138 can be used as an eight output demultiplexer by using one of the active LOW enable inputs as the data input and the remaining enable inputs as strobes. Unused enable inputs must be permanently tied to their appropriate active HIGH or LOW state.

Features:

- 5V tolerant inputs/outputs for interfacing with 5V logic
- Wide supply voltage range from 1.2V to 5.5V
- CMOS low power consumption
- Direct interface with TTL levels
- Demultiplexing capability
- Multiple input enable for easy expansion
- Ideal for memory chip select decoding
- Mutually exclusive outputs
- Specified from -40°C to +125°C
- Packaging information: DIP16/SOP16/TSSOP16/DHVQFN16

**Ordering Information:****Tube packing specifications:**

Part number	Packaging form	Marking code	Tube quantity	Boxed tube quantity	Boxed quantity	Notes
AiP74LVC138DA16.TB	DIP16	74LVC138	25 PCS/tube	40 tube/box	1000 PCS/box	Dimensions of plastic enclosure: 19.0mm×6.4mm Pin spacing: 2.54mm
AiP74LVC138SA16.TB	SOP16	74LVC138	50 PCS/tube	200 tube/box	10000 PCS/box	Dimensions of plastic enclosure: 10.0mm×3.9mm Pin spacing: 1.27mm
AiP74LVC138TA16.TB	TSSOP16	74LVC138	96 PCS/tube	200 tube/box	19200 PCS/box	Dimensions of plastic enclosure: 5.0mm×4.4mm Pin spacing: 0.65mm

Reel packing specifications:

Part number	Packaging form	Marking code	Reel quantity	Boxed reel quantity	Notes
AiP74LVC138SA16.TR	SOP16	74LVC138	4000 PCS/reel	8000 PCS/box	Dimensions of plastic enclosure: 10.0mm×3.9mm Pin spacing:1.27mm
AiP74LVC138TA16.TR	TSSOP16	74LVC138	5000 PCS/reel	10000 PCS/box	Dimensions of plastic enclosure: 5.0mm×4.4mm Pin spacing:0.65mm
AiP74LVC138QE16.TR	DHVQFN16	74LVC138	3000 PCS/reel	3000 PCS/box	Dimensions of plastic enclosure: 3.5mm×2.5mm Pin spacing: 0.5mm

Note: If the physical information is inconsistent with the ordering information, please refer to the actual product.



2、Block Diagram And Pin Description

2.1、Block Diagram

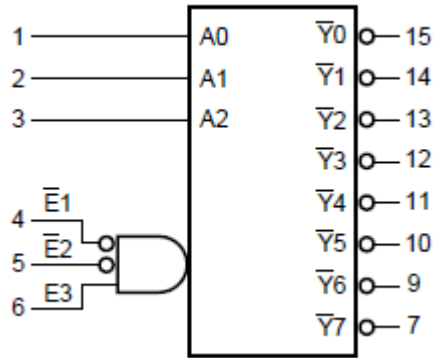

Figure 1. Logic symbol

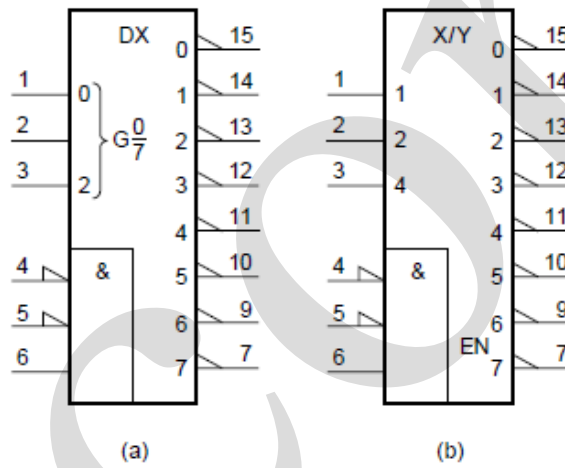

Figure 2. IEC logic symbol

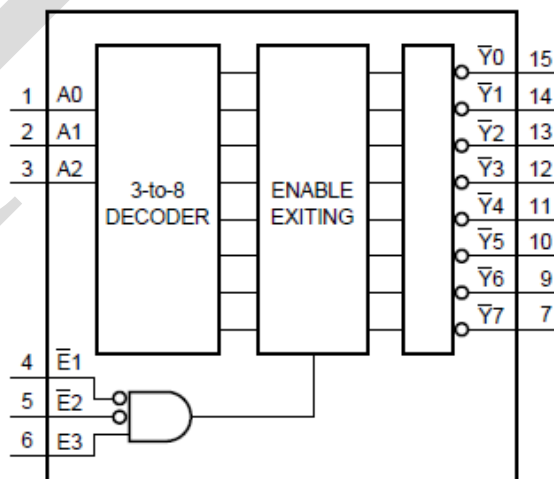
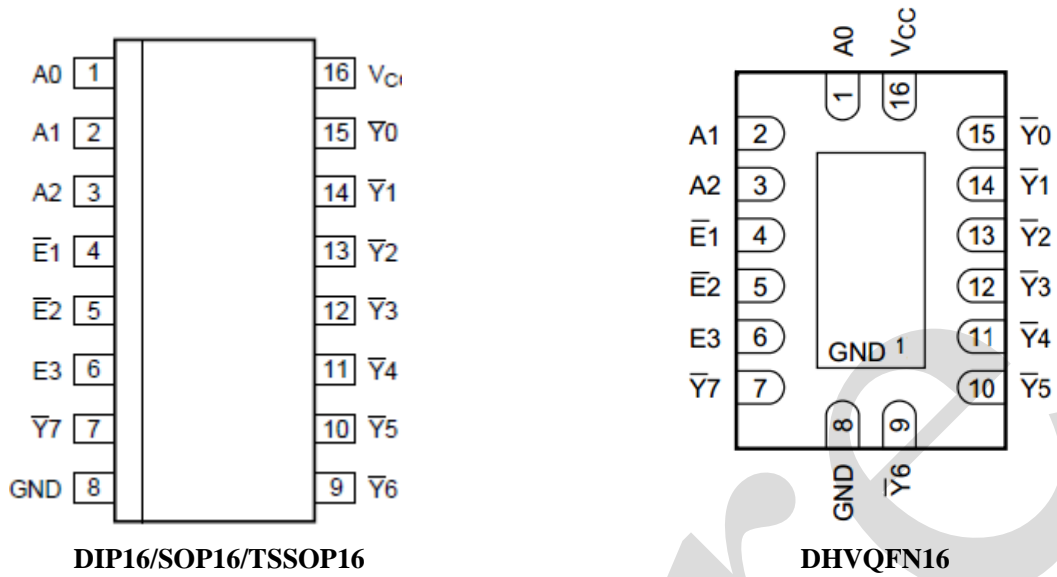

Figure 3. Functional diagram



2.2、Pin Configurations



Note:

1. This is not a supply pin. The substrate is attached to this pad using conductive die attach material. There is no electrical or mechanical requirement to solder this pad. However, if it is soldered, the solder land should remain floating or be connected to GND.

2.3、Pin Description

Pin No.	Pin Name	Description
1	A0	address input
2	A1	address input
3	A2	address input
4	E ₁	enable input (active LOW)
5	E ₂	enable input (active LOW)
6	E ₃	enable input (active HIGH)
7	Y ₇	output
8	GND	ground (0V)
9	Y ₆	output
10	Y ₅	output
11	Y ₄	output
12	Y ₃	output
13	Y ₂	output
14	Y ₁	output
15	Y ₀	output
16	V _{CC}	supply voltage



2.4、Function Table

Input						Output							
$\bar{E}1$	$\bar{E}2$	E3	A0	A1	A2	$\bar{Y}0$	$\bar{Y}1$	$\bar{Y}2$	$\bar{Y}3$	$\bar{Y}4$	$\bar{Y}5$	$\bar{Y}6$	$\bar{Y}7$
H	X	X	X	X	X	H	H	H	H	H	H	H	H
X	H	X	X	X	X	H	H	H	H	H	H	H	H
X	X	L	X	X	X	H	H	H	H	H	H	H	H
L	L	H	L	L	L	L	H	H	H	H	H	H	H
L	L	H	H	L	L	H	L	H	H	H	H	H	H
L	L	H	L	H	L	H	H	L	H	H	H	H	H
L	L	H	H	H	L	H	H	H	L	H	H	H	H
L	L	H	L	L	H	H	H	H	H	L	H	H	H
L	L	H	H	L	H	H	H	H	H	H	L	H	H
L	L	H	L	H	H	H	H	H	H	H	H	L	H
L	L	H	H	H	H	H	H	H	H	H	H	H	L

Note: H=HIGH voltage level; L=LOW voltage level; X=don't care.

3、Electrical Parameter

3.1、Absolute Maximum Ratings

(Voltages are referenced to GND(ground=0V), unless otherwise specified.)

Parameter	Symbol	Conditions	Min.	Max.	Unit	
supply voltage	V_{CC}	-	-0.5	+6.5	V	
input clamping current	I_{IK}	$V_I < 0V$	-50	-	mA	
input voltage	V_I	-	-0.5	+6.5	V	
output clamping current	I_{OK}	$V_O > V_{CC}$ or $V_O < 0V$	-	± 50	mA	
output voltage	V_O	output HIGH or LOW state	-0.5	$V_{CC}+0.5$	V	
output current	I_O	$V_O=0V$ to V_{CC}	-	± 50	mA	
supply current	I_{CC}	-	-	100	mA	
ground current	I_{GND}	-	-100	-	mA	
total power dissipation	P_{tot}	-	-	500	mW	
storage temperature	T_{stg}	-	-65	+150	°C	
soldering Temperature	T_L	10s	DIP		245	°C
			SOP/TSSOP/DHVQFN		260	°C
electrostatic discharge	ESD	HBM	2000		V	



3.2、Recommended Operating Conditions

Parameter	Symbol	Conditions	Min.	Typ.	Max.	Unit
supply voltage	V_{CC}	-	1.65	-	5.5	V
		functional	1.2	-	-	V
input voltage	V_I	-	0	-	5.5	V
output voltage	V_O	output HIGH or LOW-state	0	-	V_{CC}	V
ambient temperature	T_{amb}	-	-40	-	+125	°C
input transition rise and fall rate	$\Delta t/\Delta V$	$V_{CC}=1.65V$ to $2.7V$	0	-	20	ns/V
		$V_{CC}=2.7V$ to $3.6V$	0	-	10	ns/V

3.3、Electrical Characteristics

3.3.1、DC Characteristics 1

($T_{amb}=-40^{\circ}C$ to $+85^{\circ}C$, voltages are referenced to GND (ground=0V), unless otherwise specified.)

Parameter	Symbol	Conditions	Min.	Typ.	Max.	Unit	
HIGH-level input voltage	V_{IH}	$V_{CC}=1.2V$	1.08	-	-	V	
		$V_{CC}=1.65V$ to $1.95V$	$0.65 \times V_{CC}$	-	-	V	
		$V_{CC}=2.3V$ to $2.7V$	1.7	-	-	V	
		$V_{CC}=2.7V$ to $3.6V$	2.0	-	-	V	
		$V_{CC}=4.5V$ to $5.5V$	$0.7 \times V_{CC}$	-	-	V	
LOW-level input voltage	V_{IL}	$V_{CC}=1.2V$	-	-	0.12	V	
		$V_{CC}=1.65V$ to $1.95V$	-	-	$0.35 \times V_{CC}$	V	
		$V_{CC}=2.3V$ to $2.7V$	-	-	0.7	V	
		$V_{CC}=2.7V$ to $3.6V$	-	-	0.8	V	
		$V_{CC}=4.5V$ to $5.5V$	-	-	$0.3 \times V_{CC}$	V	
HIGH-level output voltage	V_{OH}	$V_I = V_{IH}$ or V_{IL}	$I_O=-100\mu A$; $V_{CC}=1.65V$ to $5.5V$	$V_{CC} - 0.2$	-	-	V
			$I_O=-4mA$; $V_{CC}=1.65V$	1.2	-	-	V
			$I_O=-8mA$; $V_{CC}=2.3V$	1.8	-	-	V
			$I_O=-12mA$; $V_{CC}=2.7V$	2.2	-	-	V
			$I_O=-18mA$; $V_{CC}=3.0V$	2.4	-	-	V
			$I_O=-24mA$; $V_{CC}=3.0V$	2.2	-	-	V
LOW-level output voltage	V_{OL}	$V_I = V_{IH}$ or V_{IL}	$I_O=100\mu A$; $V_{CC}=1.65V$ to $5.5V$	-	-	0.2	V
			$I_O=4mA$; $V_{CC}=1.65V$	-	-	0.45	V
			$I_O=8mA$; $V_{CC}=2.3V$	-	-	0.6	V
			$I_O=12mA$; $V_{CC}=2.7V$	-	-	0.4	V
			$I_O=24mA$; $V_{CC}=3.0V$	-	-	0.55	V
			$I_O=32mA$; $V_{CC}=4.5V$	-	-	0.55	V
input leakage current	I_I	$V_I=5.5V$ or GND; $V_{CC}=3.6V$	-	-	± 5	μA	
supply current	I_{CC}	$V_I=V_{CC}$ or GND; $I_O=0A$;	-	-	15	μA	



		V _{CC} =3.6V				
additional supply current	ΔI_{CC}	per input pin; V _I =V _{CC} -0.6V; I _O =0A; V _{CC} =2.7V to 3.6V	-	-	500	uA
input capacitance	C _I	V _{CC} =0V to 3.6V; V _I = GND to V _{CC}	-	4.0	-	pF

Note: All typical values are measured at V_{CC}=3.3V (unless stated otherwise) and T_{amb}=25°C.

3.3.2、DC Characteristics 2

(T_{amb}=-40°C to +125°C, voltages are referenced to GND (ground=0V), unless otherwise specified.)

Parameter	Symbol	Conditions	Min.	Typ.	Max.	Unit	
HIGH-level input voltage	V _{IH}	V _{CC} =1.2V	1.08	-	-	V	
		V _{CC} =1.65V to 1.95V	0.65 × V _{CC}	-	-	V	
		V _{CC} =2.3V to 2.7V	1.7	-	-	V	
		V _{CC} =2.7V to 3.6V	2.0	-	-	V	
		V _{CC} =4.5V to 5.5V	0.7 × V _{CC}	-	-	V	
LOW-level input voltage	V _{IL}	V _{CC} =1.2V	-	-	0.12	V	
		V _{CC} =1.65V to 1.95V	-	-	0.35 × V _{CC}	V	
		V _{CC} =2.3V to 2.7V	-	-	0.7	V	
		V _{CC} =2.7V to 3.6V	-	-	0.8	V	
		V _{CC} =4.5V to 5.5V	-	-	0.3 × V _{CC}	V	
HIGH-level output voltage	V _{OH}	V _I = V _{IH} or V _{IL}	I _O =-100uA; V _{CC} =1.65V to 5.5V	V _{CC} - 0.3	-	-	V
			I _O =-4mA; V _{CC} =1.65V	1.05	-	-	V
			I _O =-8mA; V _{CC} =2.3V	1.65	-	-	V
			I _O =-12mA; V _{CC} =2.7V	2.05	-	-	V
			I _O =-18mA; V _{CC} =3.0V	2.25	-	-	V
			I _O =-24mA; V _{CC} =3.0V	2.0	-	-	V
			I _O =-32mA; V _{CC} =4.5V	3.4	-	-	V
LOW-level output voltage	V _{OL}	V _I = V _{IH} or V _{IL}	I _O =100uA; V _{CC} =1.65V to 5.5V	-	-	0.3	V
			I _O =4mA; V _{CC} =1.65V	-	-	0.65	V
			I _O =8mA; V _{CC} =2.3V	-	-	0.8	V
			I _O =12mA; V _{CC} =2.7V	-	-	0.6	V
			I _O =24mA; V _{CC} =3.0V	-	-	0.8	V
			I _O =32mA; V _{CC} =4.5V	-	-	0.8	V
input leakage current	I _I	V _I =5.5V or GND; V _{CC} =3.6V	-	-	±20	uA	
supply current	I _{CC}	V _I =V _{CC} or GND; I _O =0A; V _{CC} =3.6V	-	-	200	uA	
additional supply current	ΔI_{CC}	per input pin; V _I =V _{CC} -0.6V; I _O =0A; V _{CC} =2.7V to 3.6V	-	-	5000	uA	

Note: All typical values are measured at V_{CC}=3.3V (unless stated otherwise) and T_{amb}=25°C.



3.3.3、AC Characteristics 1

($T_{amb}=-40^{\circ}\text{C}$ to $+85^{\circ}\text{C}$, voltages are referenced to GND (ground=0V), unless otherwise specified.)

Parameter	Symbol	Conditions	Min.	Typ.	Max.	Unit	
propagation delay	t_{pd}	An to \bar{Y}_n see Figure 5	$V_{CC}=1.2\text{V}$	-	14	-	ns
			$V_{CC}=1.65\text{V}$ to 1.95V	0.5	5.2	11.5	ns
			$V_{CC}=2.3\text{V}$ to 2.7V	1.5	3.0	6.5	ns
			$V_{CC}=2.7\text{V}$	1.5	3.2	6.8	ns
			$V_{CC}=3.0\text{V}$ to 3.6V	1.0	2.7	5.8	ns
			$V_{CC}=4.5\text{V}$ to 5.5V	1.0	2.3	5.0	ns
		E3 to \bar{Y}_n see Figure 5	$V_{CC}=1.2\text{V}$	-	14	-	ns
			$V_{CC}=1.65\text{V}$ to 1.95V	1.0	5.5	11.4	ns
			$V_{CC}=2.3\text{V}$ to 2.7V	1.5	3.2	6.5	ns
			$V_{CC}=2.7\text{V}$	1.5	3.3	6.8	ns
			$V_{CC}=3.0\text{V}$ to 3.6V	1.0	2.9	5.8	ns
			$V_{CC}=4.5\text{V}$ to 5.5V	1.0	2.5	5.0	ns
		\bar{E}_n to \bar{Y}_n see Figure 6	$V_{CC}=1.2\text{V}$	-	15	-	ns
			$V_{CC}=1.65\text{V}$ to 1.95V	1.0	5.6	11.5	ns
			$V_{CC}=2.3\text{V}$ to 2.7V	1.8	3.3	6.5	ns
			$V_{CC}=2.7\text{V}$	1.5	3.4	6.4	ns
			$V_{CC}=3.0\text{V}$ to 3.6V	1.0	2.9	5.8	ns
			$V_{CC}=4.5\text{V}$ to 5.5V	1.0	2.5	5.0	ns
output skew time	$t_{sk(o)}$	-	-	-	1.0	ns	
Power dissipation capacitance	C_{PD}	$V_I=\text{GND}$ to V_{CC}	$V_{CC}=1.65\text{V}$ to 1.95V	-	9.9	-	pF
			$V_{CC}=2.3\text{V}$ to 2.7V	-	15.8	-	pF
			$V_{CC}=3.0\text{V}$ to 3.6V	-	21.1	-	pF

Note:

[1] Typical values are measured at $T_{amb}=25^{\circ}\text{C}$ and $V_{CC}=1.2\text{V}$, 1.8V , 2.5V , 2.7V and 3.3V respectively.

[2] t_{pd} is the same as t_{PLH} and t_{PHL} .

[3] Skew between any two outputs of the same package switching in the same direction. This parameter is guaranteed by design.

[4] C_{PD} is used to determine the dynamic power dissipation (P_D in uW).

$$P_D=C_{PD}\times V_{CC}^2\times f_i\times N+\sum(C_L\times V_{CC}^2\times f_o)$$
 where:

f_i =input frequency in MHz;

f_o =output frequency in MHz;

C_L =output load capacitance in pF;

V_{CC} =supply voltage in V;

N =number of inputs switching;

$\sum(C_L\times V_{CC}^2\times f_o)$ =sum of outputs.



3.3.4、AC Characteristics 2

($T_{amb}=-40^{\circ}\text{C}$ to $+125^{\circ}\text{C}$, voltages are referenced to GND (ground=0V), unless otherwise specified.)

Parameter	Symbol	Conditions	Min.	Typ.	Max.	Unit	
propagation delay	t_{pd}	An to \bar{Y}_n see Figure 5	$V_{CC}=1.65\text{V}$ to 1.95V	0.5	-	12.7	ns
			$V_{CC}=2.3\text{V}$ to 2.7V	1.5	-	7.3	ns
			$V_{CC}=2.7\text{V}$	1.5	-	8.5	ns
			$V_{CC}=3.0\text{V}$ to 3.6V	1.0	-	7.5	ns
			$V_{CC}=4.5\text{V}$ to 5.5V	1.0	-	6.5	ns
		E3 to \bar{Y}_n see Figure 5	$V_{CC}=1.65\text{V}$ to 1.95V	1.0	-	12.5	ns
			$V_{CC}=2.3\text{V}$ to 2.7V	1.5	-	7.1	ns
			$V_{CC}=2.7\text{V}$	1.5	-	8.5	ns
			$V_{CC}=3.0\text{V}$ to 3.6V	1.0	-	7.5	ns
			$V_{CC}=4.5\text{V}$ to 5.5V	1.0	-	6.5	ns
		\bar{E}_n to \bar{Y}_n see Figure 6	$V_{CC}=1.65\text{V}$ to 1.95V	1.0	-	12.8	ns
			$V_{CC}=2.3\text{V}$ to 2.7V	1.8	-	7.3	ns
			$V_{CC}=2.7\text{V}$	1.5	-	8.0	ns
			$V_{CC}=3.0\text{V}$ to 3.6V	1.0	-	7.5	ns
				$V_{CC}=4.5\text{V}$ to 5.5V	1.0	-	6.5
output skew time	$t_{sk(o)}$	-	-	-	1.5	ns	

Note:

[1] Typical values are measured at $T_{amb}=25^{\circ}\text{C}$ and $V_{CC}=1.2\text{V}$, 1.8V , 2.5V , 2.7V and 3.3V respectively.

[2] t_{pd} is the same as t_{PLH} and t_{PHL} .

[3] Skew between any two outputs of the same package switching in the same direction. This parameter is guaranteed by design.



4、Testing Circuit

4.1、AC Testing Circuit

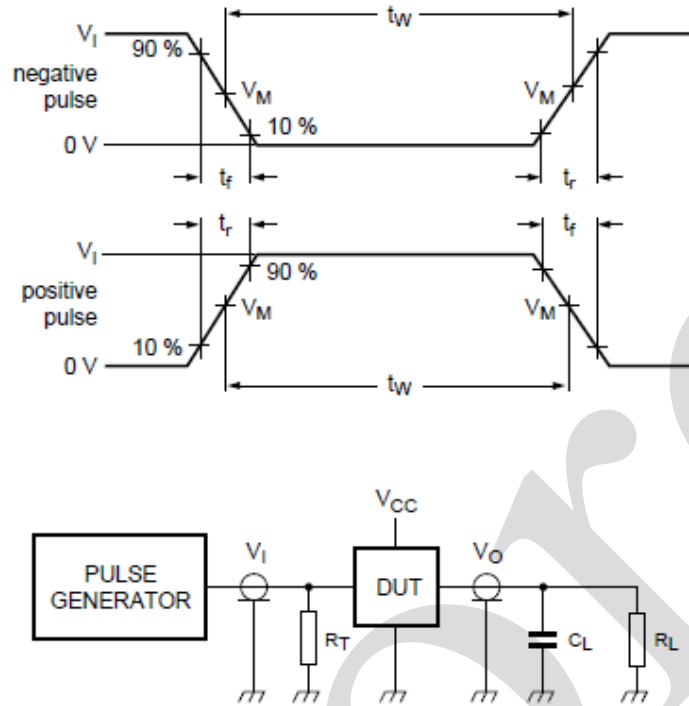

Figure 4. Test circuit for measuring switching times

Definitions for test circuit:

R_L =Load resistance.

C_L =Load capacitance including jig and probe capacitance.

R_T =Termination resistance should be equal to the output impedance Z_o of the pulse generator.

4.2、AC Testing Waveforms

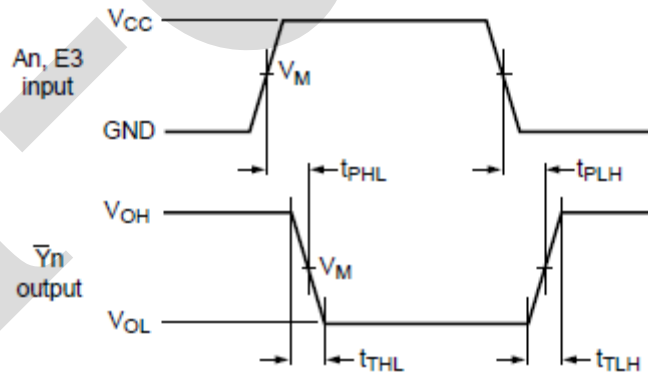
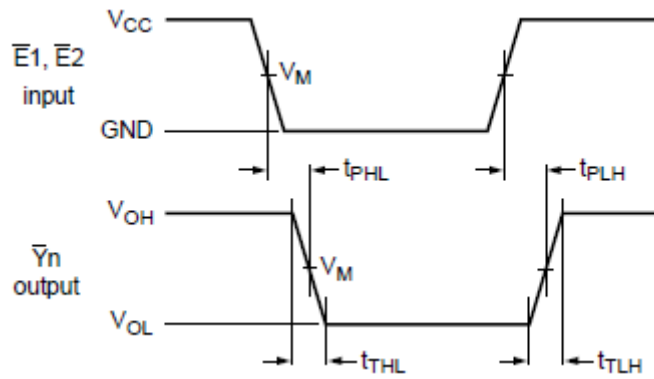

Figure 5. The inputs An, E3 to outputs \bar{Y}_n propagation delays

Figure 6. The inputs \bar{E}_n to outputs \bar{Y}_n propagation delays

4.3、 Measurement Points

Supply voltage	Input	Output
V_{CC}	V_M	V_M
$< 2.7V$	$0.5 \times V_{CC}$	$0.5 \times V_{CC}$
$\geq 2.7V$	1.5V	1.5V

4.4、 Test Data

Supply voltage	Input		Load	
	V_I	t_r, t_f	C_L	R_L
V_{CC}	V_{CC}	$\leq 2.0ns$	$30pF$	$1k\Omega$
1.2V	V_{CC}	$\leq 2.0ns$	$30pF$	$1k\Omega$
1.65V to 1.95V	V_{CC}	$\leq 2.0ns$	$30pF$	$1k\Omega$
2.3V to 2.7V	V_{CC}	$\leq 2.0ns$	$30pF$	500Ω
2.7V	2.7V	$\leq 2.5ns$	$50pF$	500Ω
3.0V to 3.6V	2.7V	$\leq 2.5ns$	$50pF$	500Ω



5、Package Information

5.1、DIP16

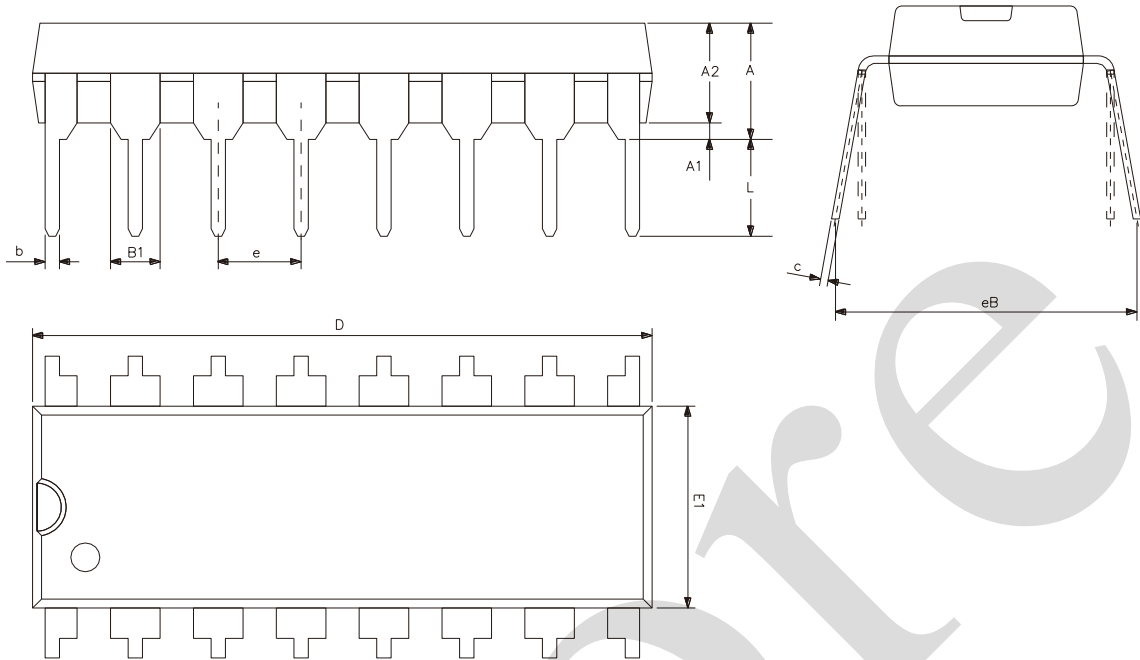

Symbol	Dimensions (mm)	
	Min.	Max.
A2	3.20	3.60
A1	0.51	-
A	3.60	5.33
L	3.00	-
b	0.36	0.56
B1	1.52	
D	18.80	19.94
E1	6.20	6.60
e	2.54	
c	0.20	0.36
eB	7.62	9.30



5.2、SOP16

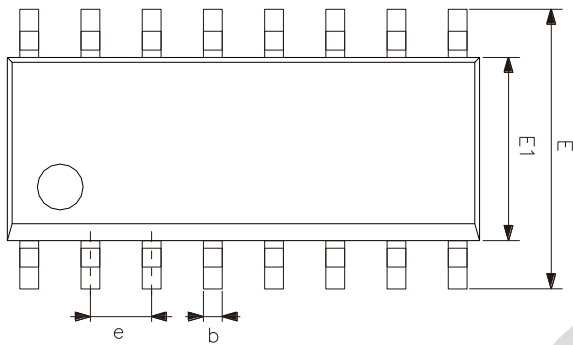
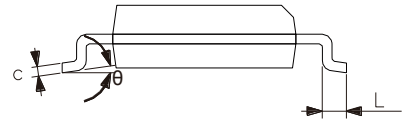
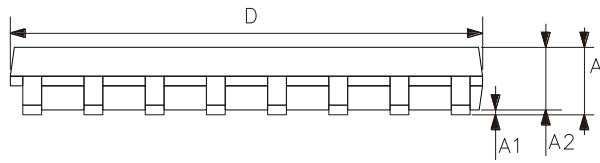

Symbol	Dimensions (mm)	
	Min.	Max.
A	1.35	1.80
A1	0.10	0.25
A2	1.25	1.55
b	0.33	0.51
c	0.19	0.25
D	9.50	10.10
E	5.80	6.30
E1	3.70	4.10
e	1.27	
L	0.35	0.89
θ	0°	8°



5.3. TSSOP16

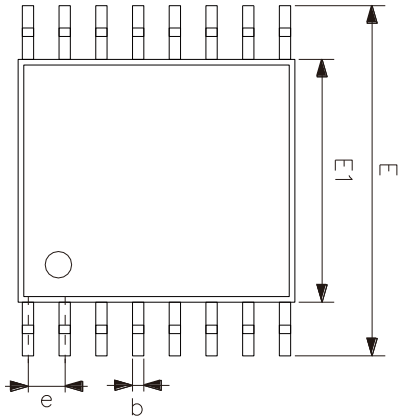
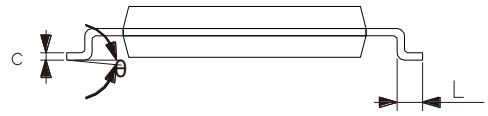
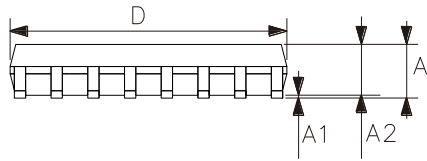

Symbol	Dimensions (mm)	
	Min.	Max.
A	-	1.20
A1	0.05	0.15
A2	0.80	1.05
b	0.19	0.30
c	0.09	0.20
D	4.90	5.10
E1	4.30	4.50
E	6.20	6.60
e	0.65	
L	0.45	0.75
θ	0°	8°



5.4、DHVQFN16

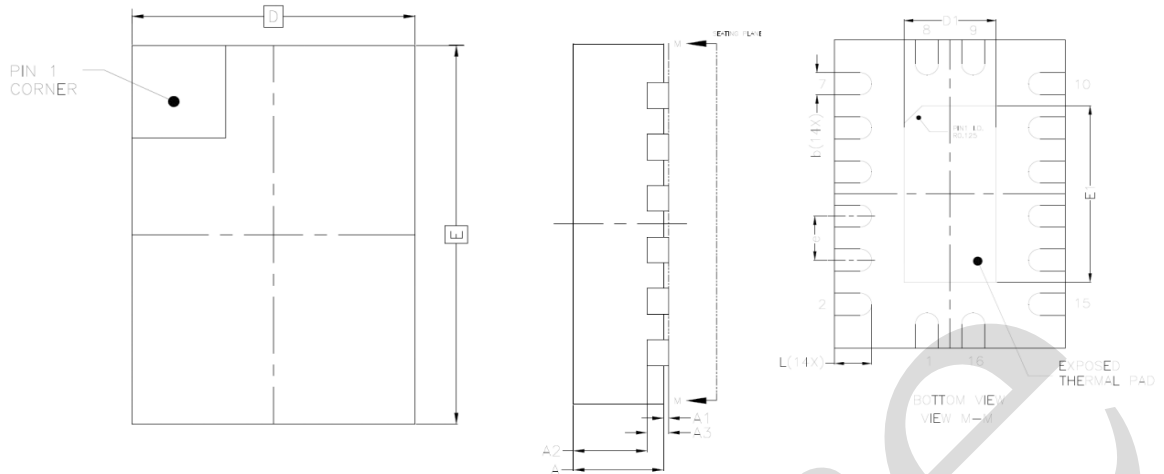

Symbol	Dimensions (mm)	
	Min.	Max.
A	0.80	1.00
A1	0.00	0.05
A2	0.60	0.70
A3	0.20	
D	2.40	2.60
E	3.40	3.60
e	0.50	
b	0.18	0.30
L	0.30	0.50
D1	0.85	1.15
E1	1.85	2.15



6、 Statements And Notes

6.1、 The name and content of Hazardous substances or Elements in the product

Part name	Hazardous substances or Elements									
	Lead and lead compounds	Mercury and mercury compounds	Cadmium and cadmium compounds	Hexavalent chromium compounds	Polybrominated biphenyls	Polybrominated biphenyl ethers	Dibutyl phthalate	Butylbenzyl phthalate	Di-2-ethylhexyl phthalate	Diisobutyl phthalate
Lead frame	○	○	○	○	○	○	○	○	○	○
Plastic resin	○	○	○	○	○	○	○	○	○	○
Chip	○	○	○	○	○	○	○	○	○	○
The lead	○	○	○	○	○	○	○	○	○	○
Plastic sheet installed	○	○	○	○	○	○	○	○	○	○
explanation	○: Indicates that the content of hazardous substances or elements in the detection limit of the following the SJ/T11363-2006 standard. ×: Indicates that the content of hazardous substances or elements exceeding the SJ/T11363-2006 Standard limit requirements.									

6.2、 Notes

We Recommend you to read this chapter carefully before using this product.

The information in this chapter is provided for reference only and i-Core disclaims any express or implied warranties, including but not limited to applicability, special application or non-infringement of third party rights.

This product is not suitable for critical equipment such as life-saving, life-sustaining or safety equipment. It is also not suitable for applications that may result in personal injury, death, or serious property or environmental damage due to product malfunction or failure. I-Core will not be liable for any damages incurred by the customers at their own risk for such applications.

The customer is responsible for conducting all necessary tests i-Core's application to avoid failure in the application or the application of the customer's third party users. I-Core does not accept any liability.

The Company reserves the right to change or improve the information published in this chapter at any time. The information in this chapter are subject to change without notice. We recommend the customer to consult our sales staff before purchasing.

Please obtain related materials form i-Core's regular channels and we are not responsible for its content if it is provided by sources other than our company.

In case of any conflict between the Chinese and English version, the version is subject to the Chinese one.